

From the *Transactions* of the
Bristol and Gloucestershire Archaeological Society

The Roman Villa, Hucclecote

by E. M. Clifford
1933, Vol. 55, 323-376

© The Society and the Author(s)

THE ROMAN VILLA, HUCCLECOTE
near Gloucester

by E. M. CLIFFORD, F.S.A. Scot.

ABOUT three miles from Gloucester, on the north side of Ermin Street, which runs from the Colonia of Glevum (Gloucester) to Corinium (Cirencester, once the second largest town in Britain), and on to Silchester and London, is Churchdown Lane, an ancient trackway leading to Chosen Hill, or Churchdown, an outlier of the Cotswold Hills, which are 3 miles away. It is composed of Upper and Middle Lias and rises to a height of 511 feet. On this there may have been a camp, but the whole area has been extensively quarried, and if there was a camp, it is now very imperfect.

On the east side of the trackway and on the southern slope of Chosen Hill (see map, FIG. 1), is a forty-acre field, now divided by hedges, called Millbridge Piece. On the north is Horsebere brook, which rises at Witcombe and joins the Severn below Longford, north of Gloucester. The Villa was in this field, 130 ft. O.D. and now about 107 ft. above the river Severn. The subsoil is alluvium on a bed of oolitic gravel derived probably from the Cotswold Hills.

The site belongs to Mr C. de Lisle Wells, of The Noake, Hucclecote, upon whose invitation this excavation was undertaken. My thanks are due to him for so unreservedly placing the site at my disposal for so long a period.

In order to find the actual site, trenches were cut diagonally across the part of the field where it was believed the last investigators dug. During the subsequent operations it was demonstrated exactly where their

holes were made, by the discovery of modern china at a depth of 4 feet 6 inches to 4 feet 9 inches. Despite the fact that the Villa was always a most accessible quarry, and was the subject of earlier investigators who published no plan or record (except a letter in *The Times* and a brief mention in *Transactions* XXXIV, 13), I venture to think that the results of the present excavation have justified the work done during the autumn of 1933.

The air-photograph (FIG. 2) and the general views (FIGS. 3-4) show the lay-out of the Villa.

Mr R. G. Collingwood defines a Villa thus¹:—

“ Villa ”, in Latin, means farm. It is an economic term ; it refers to the fact that the place so designated is an agricultural establishment. This is the sense in which we . . . use the word. There is a popular tendency to restrict its application to the country houses of the rich, with luxurious accessories and an ambitious plan ; but there is no good reason for any such restriction. Any house of the Roman period may be called a villa, provided that it was the dwelling of people, somewhat Romanised in manners, who farmed a plot of land ; as opposed to a town house on the one hand, and a cottage on the other. Most of these Romano-British farms were self-supporting economic units ; they therefore carried on other industries besides farming ; . . . as in the fulling establishment at Chedworth’.

Mr C. F. C. Hawkes writes of the building of a Roman Villa in the following words :—²

‘ Thus, in general, the plan and walling of towns both large and small appear as normal features of the first hundred years of the Roman occupation, and with these go well-built houses and ambitious public

¹ *Archaeology of Roman Britain*, 1930, p. 113.

² T. D. Kendrick and C. F. C. Hawkes, *Archaeology in England and Wales*, 1914-31, p. 260.

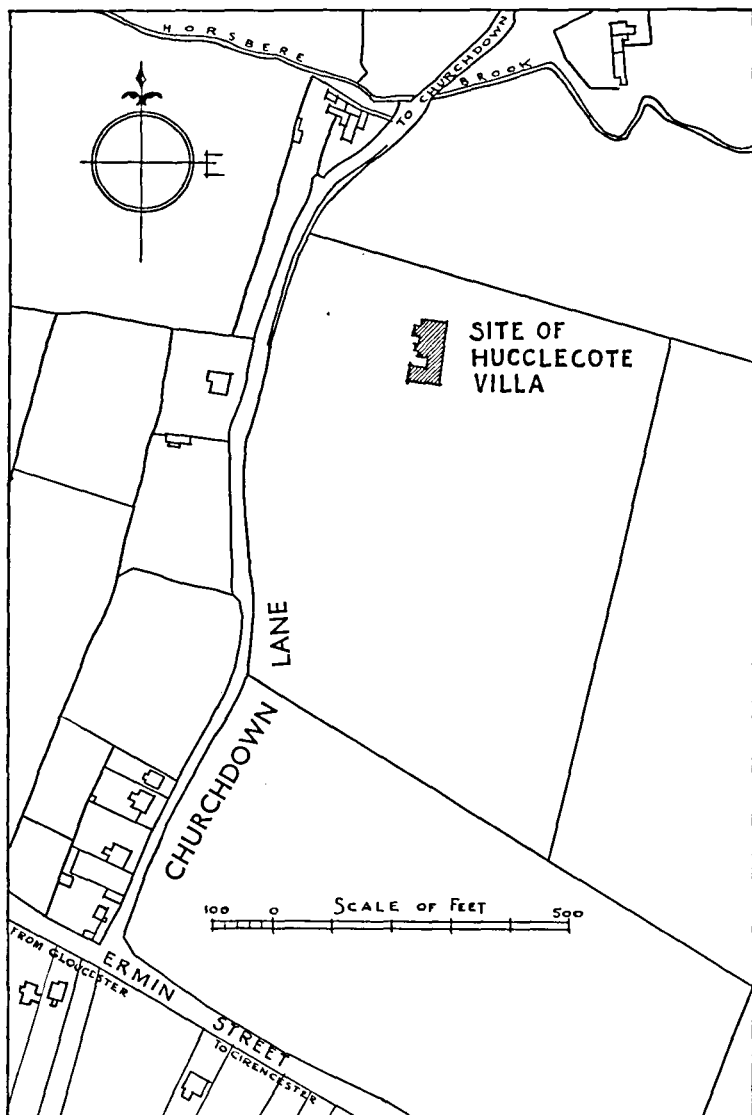

Fig. 1. Site of the Villa

buildings. After the middle of the second century, though houses may be enlarged, building standards deteriorate, and by the fourth century are undeniably low. It is exceptional for town walls to be as late as the time of the Severi (earlier third century): thereafter the normal defensive measure was the addition of bastions to walls already existing'.

We suggest that at Hucclecote, on an already occupied site a house was rebuilt for a country squire about A.D. 150. It may be presumed that the Villa was completely covered over in the Middle Ages, as none of the early county historians mentions it; and it may be further assumed that the place was disused rather than destroyed. The post-villa occupation which introduced a hearth in room v (FIG. 5) and a similar one in room XII, and used the late 4th century pottery described on page 365 may well have reached the 5th century. What the special circumstances were that allowed life to continue here it is not possible to say, but it seems certain that the Villa was occupied in the 5th century. Later, when conditions were worse, it seems possible that the occupants were no longer able to maintain it in its entirety or keep it heated with furnaces, using hearths instead.³ We do not know where they obtained their water-supply, no well or water pipes being found in the excavated area.

Gloucestershire is rich in Roman remains, and the generalization that villas were built in the 2nd century and abandoned in the 4th is largely true for the county; but the excavations of Roman villas here were undertaken in the last century, when opening and closing dates were not definitely looked for, and prehistoric occupations were not suspected. It may well be that were they re-excavated previous occupation might be proved for the other sites, as at Lydney and Hucclecote.

³ Intrusive hearths were found at East Grimstead, Wiltshire, by Heywood Sumner, F.S.A. (*Excavations*, London, 1924), and at Purwell Mill (Wymondley). Cf. Fox, *Arch. Camb. Region*, pp. 32-3, 236.

The Lydney site, as a promontory fort, had an Early Iron Age occupation from about 1st century B.C. Soon after A.D. 364-7 the temple, guest house and other structures were erected; and in the 5th and 6th centuries the prehistoric earthworks were strengthened.

At Hucclecote, a habitation-site of Late Bronze Age was discovered, as well as evidence of Early Iron Age occupation, although continuous occupation is not proved from Late Bronze Age onwards.

The Villa is of the corridor type, without wings to the front of the building (at least so far as the present excavations show) and is not exactly like any of the better known villas in the county, Rodmarton and Cherington being corridor type while Witcombe is of the courtyard type. Spoonley Wood is an example of the highest development of the bipartite plan, but the magnificent villa at Woodchester, considered the finest so far discovered, is on the block-system. The famous Chedworth villa is a developed courtyard type and is of late 2nd century date.

The Villa is small compared to the majority of villas in Gloucestershire, for the building as excavated is roughly 100 feet by 50 feet, while Chedworth is 340 feet by 238, Witcombe 215 by 122, Woodchester 300 by 325 and Spoonley Wood 199 by 175 feet. It is possible that the whole of the establishment has not been discovered, but the present building can be compared in size to Newport, Isle of Wight (102 by 45 feet), Ashstead (120 by 60), Hambleden, Bucks (95 by 70), and Rodmarton and Cherington, in this county, which are respectively 90 by 45 and 80 by 50 feet.

Mr R. G. Collingwood⁴ points out that the Romans made use of the existing British agricultural system, and throughout the four centuries of the occupation left the main principles unaltered. It seems probable that at Hucclecote a pre-Roman site was not destroyed, but that

⁴ ANTIQUITY, 1929, III, 266.

whatever building was there, the new style of house, as well as the more common forms of pottery, etc., were adopted in the 2nd century.

The building (as explained by Mr W. H. Knowles, F.S.A.) has been altered and added to many times. Rooms IV, V, and VI, at some late date, were thrown into one, and it was not until quite late in the course of the excavation that the division as shown on the plan was discovered.

There was probably a house of wood in the 1st century which was replaced by the present centre block in about A.D. 150 when room IX was probably used as baths. Pottery of 1st and 2nd century date was built into the walls of rooms XII, XX and XXI and was found under practically every floor, showing that the site was occupied during this period.

Subsequently the north wing was added and, still later, the south wing. It was altered internally many times; in some rooms there were three floors, and 4th century pottery found beneath the latest floor in rooms IV, V and VI and a coin of Theodosius (A.D. 395) on one tesserae floor and beneath another in room XV. Then comes the period when furnaces were abandoned and hearths were made, and this represents the last phase of a prolonged occupation.

A quantity of wall plaster was found. The colours are remarkably fresh and include red, pink, yellow, green, blue, brown and white, while many pieces retain their pattern. Probably the building was rendered in pink cement, some of which was in position on the western wall. Glass was scattered everywhere, including some pieces of window glass that measure 4 inches by 2.

There had been two roofs, the earlier of which was of the ordinary Roman clay roofing-tiles, the remains of which were found below those of the later Red Sandstone roof; some of the latter tiles were of large size and measured 16 inches by 10½. This Red Sandstone,



FIG. 2. HUCCLECOTE VILLA : AIR-PHOTOGRAPH TAKEN 15 OCTOBER 1933
Figs. 2-4, *ph.* Hugh Walwin



FIG. 3. HUCCLECOTE VILLA : VIEW FROM NORTH



FIG. 4. HUCCLECOTE VILLA : VIEW FROM SOUTH



FIG. 5. HUCCLECOTE VILLA: HEARTH, ROOM V (see p. 326)
ph. A. G. Spencer

which contains a large amount of haematite, was probably quarried in the Forest of Dean, and is of Old Red Sandstone age; it was used for both tesserae and tiles. The limestone used in the construction of the Villa is the local Great Oolite, while the compact Argillaceous Limestone which was used only in the centre block is of Lower Liassic age. The nearest point from which this could come is Fretherne Cliff.⁵

The mosaic pavements are of great interest inasmuch as one (room XV) is after A.D. 395. This is proved by a coin of Theodosius being found on the lower floor and under the upper one. The materials used for the tesserae are Oolitic and Liassic Limestone for the earlier floors, while for the late one both these materials and Old Red Sandstone cubes were used as well as burnt brick.

At Lydney, Sandstone cubes an inch or more square were used; at Hucclecote, we find the same in the late floor. At Lydney, they are dated after 367 and here after 395. At Lydney, they used small cubes of brick (red) $\frac{1}{2}$ inch by $\frac{2}{3}$ inch, and white and blue of local Carboniferous Limestone. Here they used local Oolite and Liassic Limestone for the white and blue, and similarly burnt brick for the red. Two floors had a scroll pattern, but very little remained of them.

Dated mosaics are rare and Dr Mortimer Wheeler, speaking of those at Lydney, says⁶:—‘As dated mosaics, they stand at present almost alone in Britain. Of the countless mosaics which have been found in Roman towns and “villas” up and down the countryside, hardly one, save two or three second-century examples found recently at Verulamium, has been even roughly dated on sound archaeological evidence’. It is interesting to find within twenty miles of Lydney another pavement, however simple, which can be satisfactorily dated; and moreover

⁵ Information from Mr C. I. Gardiner.

⁶ *Report on Excavation, Lydney Park*, 1932, p. 65.

with the same colours (although of different local material) and the same sized tesserae.

There are thus only three types of stone involved: Old Red Sandstone used for roofing-tiles and tesserae; Oolitic Limestone for building material and tesserae, and compact Argillaceous Limestone for building and tesserae.

Tufa was largely used in the construction of this Villa and was probably quarried at Dursley in Gloucestershire, where it is well exposed by the side of the tennis court at Ferney Hill. Professor W. B. R. King kindly had an analysis made of some tufa from Hucclecote which compares fairly closely with an analysis made in 1926⁷ of some from Dursley.

Mr S. E. Winbolt has recorded tufa used in Roman work in Kent, Sussex, Wiltshire and possibly North Wales.⁸ It was certainly used at Witcombe and Chedworth in this county, and Keynsham in Somerset.⁹ During the visit of the British Archaeological Association to Duntisbourne Rous church in 1869 the Rev. J. G. Joyce stated that 'tufa was a favourite stone used by the Romans, and did not exist in England'.¹⁰

The pilae were all of baked brick; some measured 11 inches by 8½, and one showed footprints of roe deer.¹¹ The late Professor J. H. Middleton pointed out in his account of Spoonley Wood¹² that while 'in Italy the pilae seem to have been always formed of baked brick, but in some parts of England, especially in Gloucestershire, bricks seem to have been costly, and are very sparingly used. Thus . . . at the fine Villa at

⁷ *Procs. Cotteswold Club*, xxii, 267.

⁸ *Antiquaries Journal*, v, 421-2.

⁹ *Journ. Roman Studies*, 1923, xiii, 265.

¹⁰ *Journ. Brit. Arch. Assoc.*, 1869, xxv, 307.

¹¹ Opinion of Dr O. Wild.

¹² *Archaeologia*, 1891, lxi, 665-6.

Chedworth . . . nearly all the pilae are made of stone, in spite of the local stone being a soft oolite which has no great power of resisting fire'.

Three trenches were found on the west side of the Villa. All the datable remains recovered from them were Roman (1st-4th centuries). No. 1 (*see* PLAN, p. 340) was 5 feet 6 inches deep by 6 feet wide at the top, its sides carefully formed and lined with clay. In it was almost the whole of the 1st and 2nd century Samian ware with the exception of a part of a dish (FIG. 20) found in no. 3 (the remainder of the dish being found in no. 1). In no. 1 was a human skull without any other part of the skeleton, a canine tooth of a bear (FIG. 6), animal bones, and shells. The other trenches were smaller than no. 1; no. 2 was circular in section and lined with rough stones; no. 3, v-shaped in section and unlined.

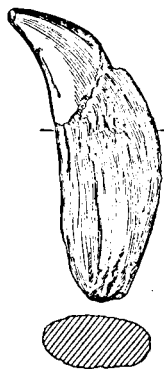

Fig. 6 ($\frac{1}{2}$)

A section was cut across all three trenches to a depth of six feet; it was found that under the soil at a depth of 3 feet there was a bed of clay (alluvium) under which there lay a bed of oolitic gravel. (No. 1 trench was cut through the clay into the gravel). This would be true for the whole of the site of the Villa. Dr K. S. Sandford's report on this is appended (p. 375).

Almost in the centre of the building, on the east side, a habitation-site of the Late Bronze Age was discovered. It was semi-circular and carefully made, but unfortunately had been destroyed by Roman walls at the north and south ends. The trench was filled with a yellow clay which entirely encompassed the evidence of human occupation. It may be assumed that the climatic optimum of the Late Bronze Age (sub-boreal times), when the proximity of the Horsebere brook would be a distinct

advantage, made this a desirable habitation-site, and the succeeding wet phase (sub-atlantic) may well have laid down the clay which overlies it, as it is really at the foot of Chosen Hill, which is composed of Upper and Middle Lias. This would fit with Dr Sandford's report.

In the small portion of the trench which remained, some flints (FIG. 7), two pebbles and a good deal of

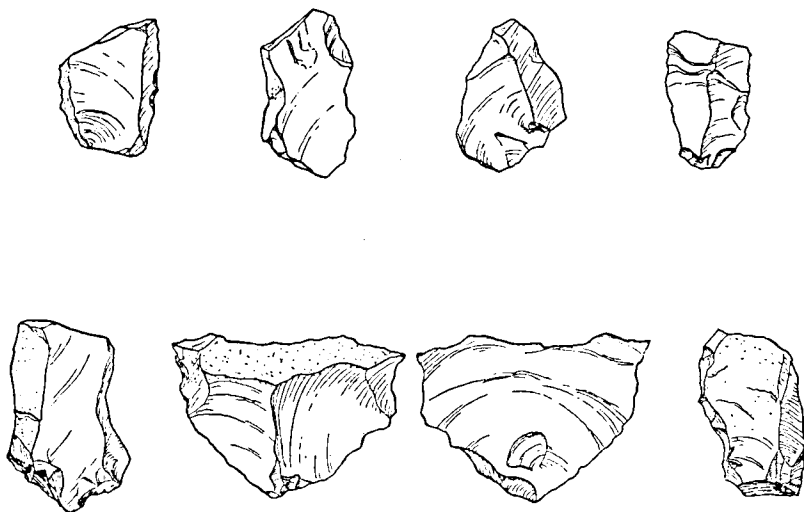

Fig. 7 (4)

Deverel-Rimbury pottery (FIG. 23) was recovered, parts of three vessels being found. Deverel-Rimbury pottery has recently been the subject of a study by Mr Christopher Hawkes,¹³ who records only one other site in Gloucestershire (a barrow interment at Nether Swell) for these Lower Rhenish urnfield invaders, while only eleven other habitation-sites are recorded in England. It may be dated 700-600 B.C. The trench was 4 feet 6 inches below

¹³ *Antiquaries Journal*, XIII, 414.

the surface and 2 feet wide at the top (below level of villa floor); the base was rounded. At this point, it may be recorded that while this work was in progress about twenty flints, probably Bronze Age, were found in the field.

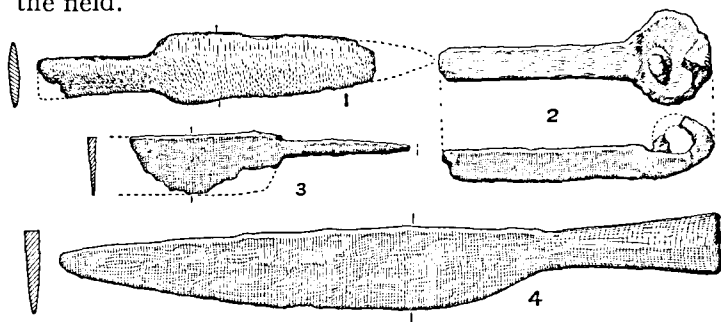

Fig. 8 (1)

1. Lance head of iron, roughly made, with whole (not split) socket imperfect at end, the faces of the blade nearly flat. L. 5.3 inches.

2. Part of iron linch-pin for cart-wheel, end of shaft missing, square section, flattened and expanded at the head which has a broken loop on the concave side. L. 4.3 inches. The loop was for attaching a chain or other fastening to prevent loss. Simple form of fig. 36, British Museum R.B. Guide.

3. Tanged knife of iron, with straight back and semicircular cutting-edge, the blade perhaps originally triangular, broken at point. L. 4.4 inches. Similar knives, but with sockets, are figured in Jacobi's *Saalburg*, pl. xxxvii.

4. Knife blade with socket for a long handle or haft, thick straight back, and blade tapering to the point. L. 10.7 inches. A socketed knife about 12 inches long from an Early Iron Age site at Varimpré, Seine-inférieure, is figured in *Arch. Journ.*, LXXXVII, 215, fig. 17, no. 2.

Mr G. C. Dunning drew attention to slight evidence of an occupation trench under room v. This was investigated and immediately under the second floor red roofing-tiles were found (the first roof of the Villa), broken building material, plaster and coal.¹⁴ Lower down a spear head

¹⁴ (1) Dr W. N. Edwards of the Natural History Museum kindly examined this coal, but cannot say with certainty where it came from, probably Dean Forest. (2) Coal is recorded at Witcombe, Spoonley Wood, and Woodchester in this county, as well as twelve other sites in England.

(FIG. 8, no. 1) was found, and at the base of the trench a quantity of split bones, a leg bone of fowl, an iron object thought to be a brooch, and fragments of pottery of the Early Iron Age.

Under the floor of room xv there was a post-hole roughly lined with stone and probably of Early Iron Age date (similar ones were found at Salmonsbury, Bourton on the Water, in 1933). It will be seen from the photograph (FIG. 24) how completely the Roman walls destroyed any further evidence of Early Iron Age occupation.

The interior of the Villa contained few small objects.

The fragments of glass to which references have been made earlier included a bowl (FIG. 10) described by Mr Reginald Smith as of thin pale-green glass (restored) with 7 oval depressions and slightly indented base, the lip out-turned at an angle. D. 5 in. Like one from Pezou (Loir-et-Cher) in Morin-Jean, *La Verrerie en Gaule*, p. 194, fig. 255.

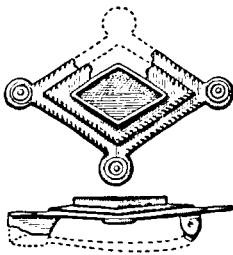

Fig. 9

Other fragments of glass bowls were found as well as window glass.

On the west side of room 1 a brooch was found (FIG. 9). It is of lozenge form with raised centre (setting lost) and projecting disks at the angles with ring-and-dot pattern. L. 1.2 inches. A 2nd century type, originally enamelled.

Also from this west side came a decayed sandal with hobnails, and tiles from rooms VII and IX marked by hobnails before burning.

Only 26 coins were found ; one of 1st century, 2 of 3rd, and 22 of 4th century. In the earlier excavation (1910) coins of Valentinian I, Valens, Valentinian II, and Honorius were found¹⁵.

¹⁵ Letter to *The Times*, 22 February 1911, by the late Canon Bazley.

If we exclude Lydney (which as a religious centre cannot be compared with a villa-site in this connexion) this is the only Villa in Gloucestershire where such late coins have been found.

Mr R. G. Collingwood says that with the exception of villas in Kent and Somerset, all villa coin-lists end with Valentinian I and Valens at latest.

Inscribed tiles (FIG. 21) and the graffito drawing of a house (FIG. 22) were found in the infilling of the building and immediately outside. The tiles found on this site

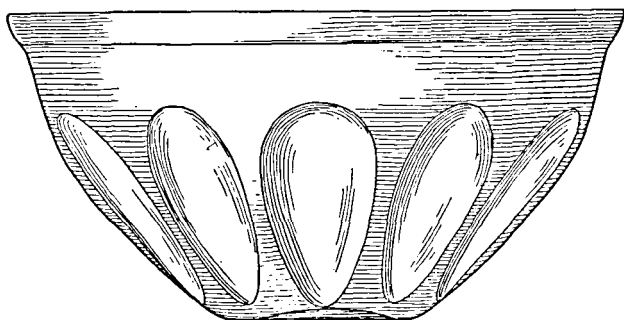

Fig. 10

in 1910 as well as those from Dryhill and Ifold in this county, are recorded,¹⁶ while another one of the series was discovered in the Romano-British cemetery at Barnwood, assigned to the 1st-2nd centuries A.D.¹⁷

Other objects included bone pins, a bodkin, knives, (FIG. 8, 3) keys, rings, spindle whorls, bone counter, quern of trachyte or volcanic grit from the neighbourhood of Andernach on the Rhine. Also discs for 'fivestones',¹⁸

¹⁶ *Ephemeris Epigraphica*, IX, fasc. 4, nos. 1283, 1284, 1287.

¹⁷ *Trans. B.G.A.S.*, LII, 229.

¹⁸ *Journ. Roman Studies*, 1926, XVI, 38-44.

buckles, nipped bases of 4th century vases for draught games, linch pin (FIG. 8, 2), lock escutcheons, etc.

One fragment of Carrara marble was discovered. The only piece of sculpture is of oolitic limestone and is the shoulder and part of the arm of a statue.

Just outside the corridor on the east side a jaw of a child was found close to the wall, on a level with the bottom of the foundations, while under the floor of room XIX other parts of skeletons were discovered.

A large number of iron objects were found, including many nails, some of which remained in the roofing-tiles. Though it is not possible to say where this iron was made it is well known that the Romans used the Forest of Dean ores. One mine was found at Lydney (*Lydney Report*, p. 18), and other workings are known.

POTTERY

The only pottery kiln recorded for Gloucestershire was at Tidenham, but no details are known.*

The pottery from the site may be presumed to represent the household needs for the period of the Romano-British occupation. With the exception of Lydney there is, unfortunately, little dated material from a villa in the county and it is to Lydney that we must turn for comparison with our later pottery, which is the most interesting.

Chedworth, Spoonley Wood, and Wadfield, are the only Gloucestershire villas previously excavated where any pottery has survived, and these have not been published in detail. Through the kindness of Major Dent-Brocklehurst, the Spoonley Wood and Wadfield pottery was examined, and it appears to correspond to Chedworth, and range from 2nd to 4th century. The pottery found at Barnwood, about three quarters of a

* Information from Mr Heywood Sumner, F.S.A.

mile away from Hucclecote, can be used for comparison for the first two centuries.

The ware of native character or tradition is represented by a number of jars (FIG. 29, nos. 83 to 89). Some of this is early, while a base was found under the three floors of room v. Definite undercutting of the lip of the jar is present as at Runcton Holme, Norfolk,¹⁹ where it occurs in a 1st century type. Dr R. E. M. Wheeler has kindly examined some of these later native sherds and points out that no. 89 is similar both in shape and texture to Lydney type 23, and while no. 84 represents an early tradition at Colchester and elsewhere, they are particularly characteristic of the 4th century, and may safely be ascribed to that period in the Lydney context.

Mr G. C. Dunning informs me that this ware at Salmonsbury, Bourton on the Water, is 3rd and 4th century although it has not yet been worked through. There are two or three pieces of the same kind at Chedworth, where there is also late colour-coated ware of 4th century. There is also a little in Gloucester Museum from the Kingsholm area. On the other hand, it was certainly in use at Hucclecote in the 1st and possibly the 2nd century. Mr Hawkes points out that ollae with everted rim fill the place of this in the later period, so perhaps a recrudescence took place here in the 5th century.

There is an appreciable amount of 1st century pottery, both Samian and coarse. This includes parts of seven Samian vessels, forms 31 and 33, while the Belgic type jars, dishes, and amphorae (type 80, Caerleon A.D. 90-130) are of the same period. In the 2nd century, cooking jars, mortaria, pie dishes and Samian pottery were in general use. There are rims of Samian forms 18/31-29, 31, 33, 36, 37 and 38; 38 being by far the commonest. In the 3rd century the imitation Samian replaces Samian,

¹⁹ *Proc. Prehist. Soc. of East Anglia*, VII, 290, fig. 34.

and this is well represented. There is late red coated ware (after A.D. 350) and of this we have an appreciable amount. The ollae range from A.D. 150 to about 400. The mortaria are all of 3rd-4th century. The pie dishes are 2nd-4th century.

SUMMARY

The site was undoubtedly occupied in the Late Bronze Age (700 B.C.) and again during the Early Iron Age. It is highly probable that from the 1st century A.D. until some time in the 5th century, it was continuously occupied.

I am much indebted to many friends for their help so readily given. First to Mr W. H. Knowles (for his plan and report on the buildings, and without whose constant help it would not have been possible to undertake the work). Mr Reginald A. Smith, of the British Museum, Mr C. F. C. Hawkes, Dr J. Wilfrid Jackson, Sir H. C. H. Carpenter, Miss Dorothea Bate, Miss M. L. Tildesley, Mrs M. C. Burkitt (for drawings of flints), Dr Wallis, Mr E. Camm, Mr D. N. London, Mr C. H. V. Sutherland, Dr W. B. R. King, Mr M. A. C. Hinton, Mr A. S. Kennard and Mr W. Leah, have one and all most willingly given advice or contributed the reports on special features of the excavations which are printed in the Appendix to my notes, and to them I am most grateful.

APPENDIX

I. NOTES ON THE BUILDINGS

by W. H. Knowles, F.S.A.

Roman sites abound within a few miles from the Villa at Hucclecote: below Cooper's Hill is the important Witcombe Villa,²⁰ on Crickley the lesser remains of Dryhill,²¹ and within a dozen miles the interesting Chedworth,²² Spoonley Wood,²³ and Woodchester,²⁴ considered the finest Roman-British villa yet revealed in England.

In the autumn and winter of 1910-11 the site was subjected to investigations by excavators who left neither record nor plan of their activities. The operations conducted in 1933 cover an area measuring 102 by 53 feet, but it is highly probable that the whole of the establishment has not been explored, as at the north angle (about room v) are broken walls. The buildings present an unbroken frontage to the east, with a central block approximating in plan to the corridor type of villa and flanked with wings at either end projecting westwards. On the west, the site was bounded by a ditch long since obliterated by the plough. (SECTION and PLAN, FIGS. II-12, p. 340).

²⁰ S. Lysons, *Archaeologia*, 1821, XIX, 178; St. C. Baddeley, *Trans. B.G.A.S.* 1907, XXX, 246.

²¹ W. H. Gomonde, *Notes on Cheltenham*, 1849, pp. 7-13.

²² J. Farrer, *Proc. Soc. of Antiq. Scotland*, 1868, VI, 278; J. W. Grover, *Journ. B.A.A.*, 1868, XXIV, 129; H. M. Scarth, *ib.* 1869, XXV, 215; G. E. Fox, *Arch. Journ.* 1887, XLIV, 322; A. T. Martin, *Proc. Clifton A. C.*, 1893, II, 57.

²³ E. P. L. Brock, *Journ. B.A.A.* 1882, XXXVIII, 215, and 1895, N.S. I, 242; J. H. Middleton, *Archaeologia*, 1891, LII, 651.

²⁴ S. Lysons, *Woodchester*, 1797; C. Playne, *Trans. B.G.A.S.* 1880-1, V, 142; A. A. L. Payne, *Roman Villa, Woodchester*, 1926; St. C. Baddeley, *Trans. B.G.A.S.* 1926, XLVIII, 75.

ROMAN VILLA · HUCCLECOTE NEAR GLOUCESTER ·

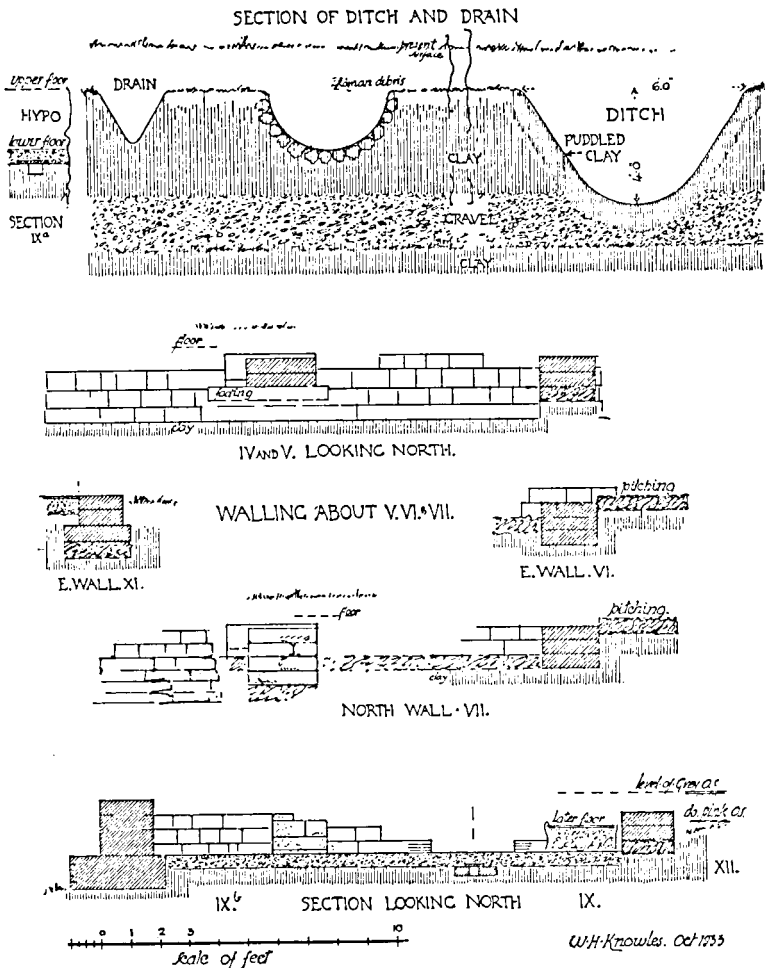

Fig. II

ROMAN VILLA
HUCCLECOTE
NEAR GLOUCESTER

W.H. KNOWLES.
MENS ET DEL.
OCTOBER, 1933.

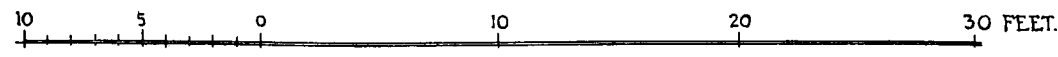
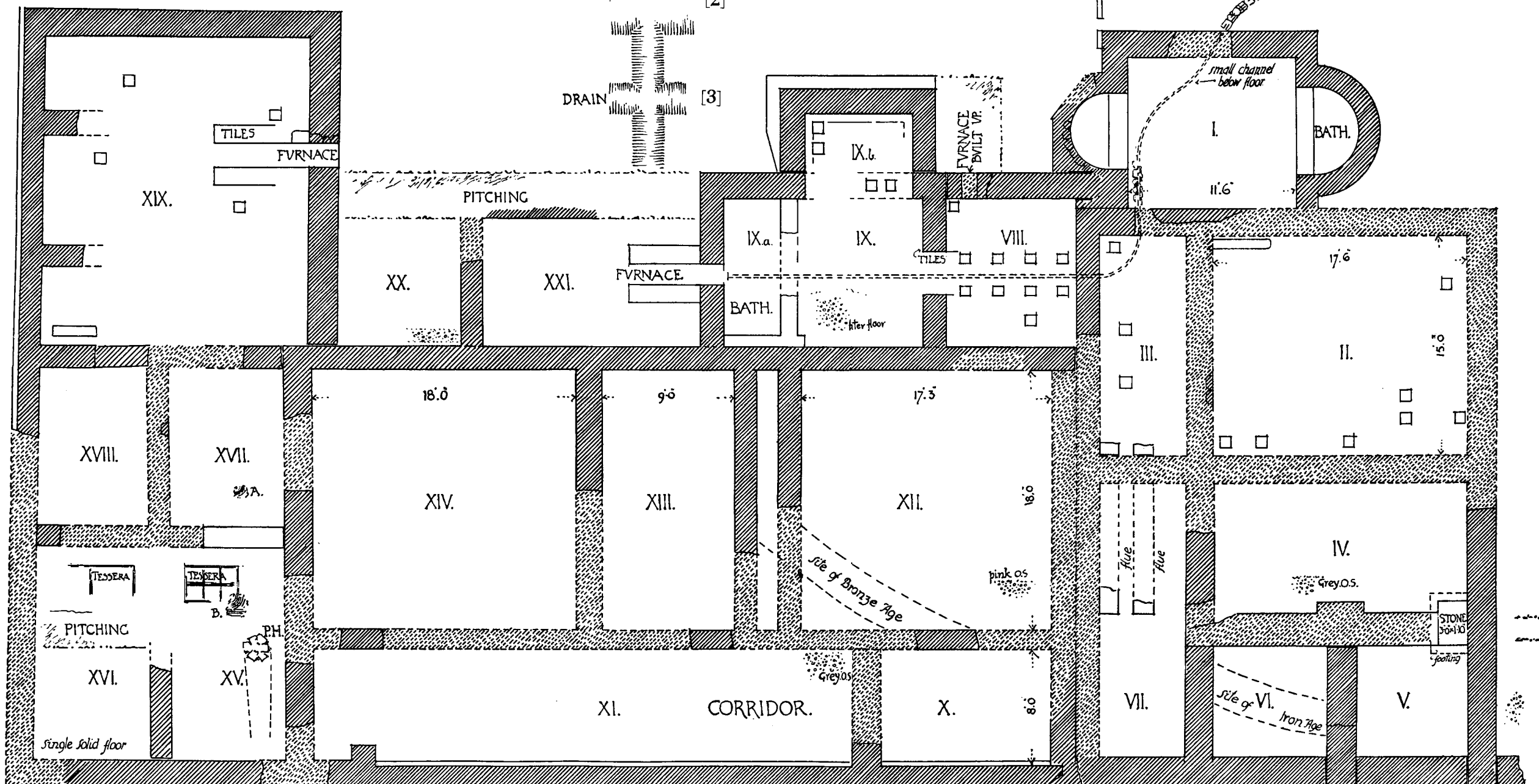
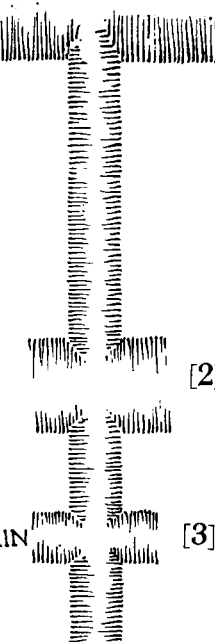
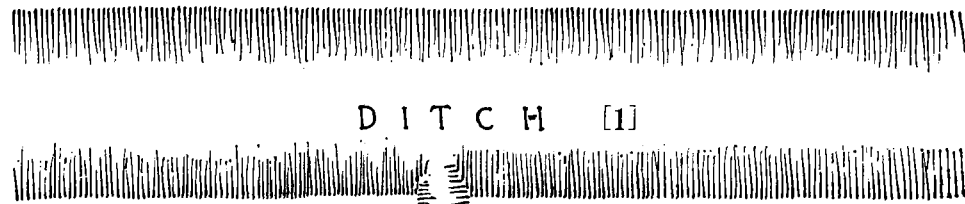

Fig. 12

The general floor-level is only 12 to 18 inches below the present surface. Masonry nowhere exists above the floor level, indeed much of the walling has been entirely grubbed up; and so effective has been the removal of building material, that not a single moulded stone, a threshold or even a channel stone has survived. The walling (FIG. 13) is of oolitic limestone, roughly dressed and clumsily laid in courses. In workmanship it is much inferior to the masonry of well dressed squared stones to be observed in Hadrian's Wall²⁵ and the enclosing walls of Glevum,²⁶ both government products. Clay underlies the site, and is encountered three feet below the surface.

The structures are not of one build, but comprise a series of operations, additions and alterations effected during a long period of occupation, from the 2nd-4th century. These we will proceed to describe and tentatively regard as one unit.

The central block comprises a corridor 8 feet in width which gives access to four rooms, X, XII, XIII, XIV, the largest, XIV, being 18 feet square. Between XII and XIII are two walls near together which may have carried a stair and formed near the corridor a lobby giving access to rooms XII and XIII. All were covered by two solid opus signinum floors, that of the earliest occupation was 12 inches below the upper, over which are occasional indications of flooring only a few inches in thickness, possibly representing another period or evidence only of repair or reflooring. The floors have a polished surface of broken tiles bedded in gravel over stone pitching, sometimes laid in herring-bone fashion. The secondary floor is of the same height as that of the wing floors. Near the west end of the twin walls the masonry was overlaid by a thick layer of opus signinum where there

²⁵ *Arch. Aeliana*, ser. 4, VIII, 256.

²⁶ *Trans. B.G.A.S.* LIII, 272, plate vi.

may have been an opening (below the stair) giving on to IXA, when it and IX were first erected (see below).

The walling on the east side, and the return walls of X and XII are of roughly dressed stone, indifferently laid in courses over a wide footing (FIG. 14) set on a course of stone pitching. In technique it is unlike the masonry employed in the wing section, and further includes many Liassic stones which are elsewhere absent. The south and west walls are of poor construction and much dilapidated. Conceivably the section (the central block) originally extended north and south on the site of the flanking wings as we now see them. On the west side also are added buildings comprising first a single room IX, IXA, to which was added VIII and IXB. All were heated by pillared hypocausts, the level of the lower floor of which is strangely some inches below the foundations of the west wall of XII, XIII, XIV. Together the rooms are suggestive of a small bath building which was combined with, or gave place to, a more ambitious scheme to be associated with room I. The masonry of the addition resembles that of the section with the exception of the massive walls below the floor of IXB (FIG. 13), which were, no doubt, in part intended to carry a water tank. At the south end of IX, is a bath with a dwarf wall to IX which retains, on both wall and floor, portions of coloured cement. At the east end of the bath, a few stone courses screen the difference in level (see below) between the foundations of the wall proper and the lower floor of the hypocaust, which in VIII is masked by tilting the floor at the point. The suspended floor of the hypocaust was supported by tiled pilae, and heated by a furnace with tiled cheeks situated in XXI. In the west wall of VIII, was another stoke-hole subsequently built up, following, no doubt, on the curtailment of the chamber by the penetration of the structures peculiar to the north wing. See the west wall which proceeded beyond the limits of room VIII. (FIGS. 12 and 17).

Below the floor level, and proceeding (without side branches) down the middle of IXA, IX and VIII (FIGS. 12, 15, 19) is a small channel or flue. Under IXA and IX it is about 6 by 3 inches, formed in the clay and with a stone slate cover embedded in, and flush with, the underside of the hypocaust floor. Below VIII the opening measured $4\frac{1}{2}$ by $3\frac{1}{2}$ inches and had a small stone, on either side of which the covering slate rested. The channel passed through the north wall of VIII, and in a rudely constructed form with sides and cover of unshapen stone was continued not only below I but beyond it into the open. (FIG. 16).

The channel did not exist within the stoke-hole, but as indicated on the plan started from the side of the first cover stone 4 inches away from the face of the wall, but not to be connected with a box tile or other vertical shaft which would have blocked the stoke-hole at the point. The channel is sealed on the top and without visible inlet or other openings; at the furnace end it was choked with charcoal and below room I filled with lime deposit.

The purpose of similar, but larger, channels below hypocaust floors has been much discussed, and considered by some to be associated with the admission of fresh air into the rooms above, the inlet being strangely in the vicinity of the stoke-hole²⁷.

At Hucclecote, the channel can scarcely be associated with ventilation. It has a fall of 9 inches to the outlet at the north end and possibly served as a sort of sump or a field drain below the floor and escape for storm water about the furnace, an occasional present-day provision where at this depth drains are non-existent. (FIGS. 11,

²⁷ Sir George Macdonald, 'The Bath House, Cilurnum', *Arch. Aeliana*, ser. 4, VIII, 284; *Lydney Report*, 53.

12, 16).²⁸ At a later date room IX was covered with solid opus signinum 12 inches thick above the lower hypocaust floor.

The area of XXI was probably an open space and XX, with slight remains of floor and enclosing wall, a fuel store. There are no drain stones of the usual form about the area, but shallow v-shaped ditches or channels, 18 inches deep, in the clay which may have sufficed to convey waste water to the ditch* enclosing the site on the west (FIG. 11). A wide stretch of stone pitching occurs by the side of XX and XXI, on the inner edge of which are a few facing stones. Patches of similar pitching will also be observed running alongside the east wall of the corridor and possibly served for the foundation of a footpath. By the side of the pitching where shown on plan are two dressed stones. In the vicinity of the ditch (the back door of the place) was a quantity of broken wall plaster coloured in a variety of colours and decorated with scroll and other patterns, together with a number of hexagonal roofing slates, a few of them with the nails with which they were secured.

About rooms I, II, III (the north wing), there are but a few fragments of masonry bordering the rooms. All were heated by pillared hypocausts: the floors were supported on tiled pilae, excepting a portion of III (FIGS. 12, 16) where channels are indicated. The site of the furnace was to the west of room I where are some indefinite scraps of pavement of both red cement and stone pitching, the former the site of the usual water tanks or cauldrons, and the pitching that of the furnace. Strewn about the area were a number of stone voussoirs evidently belonging

²⁸ Bearing in mind the possible use of the channel for ventilation, but regarding the inlet for fresh air as at the north end, and to be admitted to the chamber at the south near the stoke-hole, the site was explored but no branches to avoid the stoke-hole were found.

* Mr Kennard's report (App. XI) shows that it contained water but was liable to desiccation in the summer.



facing p. 344

PLATE V

FIG. 13. HUCCLECOTE VILLA : ROOM IX, SHOWING OFF-SET OF WALL (*see* pp. 341, 342)
Figs. 13-20, *ph.* Hugh Walwin



FIG. 14. EAST WALL : PITCHING ON OUTER FACE AND OFF-SET
ON INNER FACE (*see* p. 342)



FIG. 15. HUCCLECOTE VILLA: NORTH END FROM WEST SIDE, SHOWING APSIDAL BATHS AND COVERED CHANNEL, ROOMS VIII AND IX (*see* p. 343, and fig. 16)



FIG. 16. HUCCLECOTE VILLA : COVERED CHANNEL, ROOM III (*see* p. 343)



FIG. 17. HUCCLECOTE VILLA : APSIDAL END, ROOM I (see p. 345)



FIG. 18. HUCCLECOTE VILLA : FLOOR ROOM XV, WITH FRAGMENT OF LATER
TESSERAE-PAVING ABOVE (*see pp. 346-7*)



FIG. 19. HUCCLECOTE VILLA: COVERED CHANNEL, ROOM VIII (*see* p. 343)

PLATE XII



FIG. 20. HUCCLECOTE VILLA: FRAGMENT OF LATE LEZOUX BOWL, FORM 37 (see pp. 331, 354)

to the arch of the stoke-hole. Room I (11 feet 6 inches by 10 feet 3 inches) has at either end an apsidal projection intended for bath and laver with dwarf walls to the chamber. The outline of the northern apsidal recess could be easily traced and that of the south still retained some stone penning, a single flag and vestiges of red cement (FIG. 17). The south apse is smaller than the north, its size being dictated by the early masonry of VIII. About rooms II and III are occasional stones defining their size and shape, and the lower courses of the tiled pillars of the hypocaust. Rooms IV, V, VI and part of VII, were floored with opus signinum at the height of the secondary floor of rooms X–XIV. At the north end of the walling between IV and V is a large stone 30 by 22 by 18 inches, set in cement over a footing-course, either intended to support a tank, or the base of a pilaster, although there is no corresponding block at the south end of the wall. In the centre of its length, the foundation shows a projection or possible provision for a pier. This wall and that on the east side of V overlap those adjacent to them and are assumedly insertions. The north wall of the wing, and the wall between V and VI, extend beyond the limits of the excavations. The east wall also was continued northwards, where is debris of destroyed walls and flooring. The rooms of the wing (I to VII) were constructed at one time. They necessitated the curtailment (about room VIII) of pre-existing buildings of which there is no trace excepting the evidence that its west wall proceeded northwards of the new south wall of III, and dictated the form of the apsidal projection. The whole of the masonry of this wing is of even courses and altogether superior to the contiguous work. The foundations of the walls are also at a lower level and are without the broad projecting footing-courses of the external wall of XI. It was a considerable addition, and if—a permissible inference—the whole is to be interpreted

as forming a suite of bathing rooms, is not without significance, bearing in mind the extent of the accommodation already described (FIG. 12). In the absence of the actual floors and the details with which they are usually furnished, it may seem unwise to speculate on the functions served by rooms I to VIII. Though the grouping of the apartments is so strikingly like the combination or suite common to a bathing establishment, it may be conjectured that VII served the purpose of an entrance or apodyterium, IV that of a frigidarium with cold bath, at V or VI, and II that of a tepidarium leading into I, obviously the caldarium. It may be further surmised that VIII and IX, an earlier tepidarium and caldarium (when the stoke-hole below the former was built up), became a sudatorium for those who preferred perspiration by dry heat—unless women's baths—and III or VIII possibly an unctorium where unguents were applied.

The area of the south wing (XV to XIX) has been piteously plundered. It is probable that the whole or part of the eastern half (before alteration) was contemporary with, and formed part of, the first or corridor building. Confirmation of this is to be observed in the eastern wall, which is of the same technique as the corridor block. The inner corridor wall also clearly extended across the pitching left below XV and XVI, and similarly the western walls of rooms XII and XIV, across XVII and XVIII. The division between XV and XVI is of a few large stones only without foundation; that between XVI and XVIII and between XV and XVII, is also of shallow description in three courses, the uppermost flag-like. The projecting footing outside XV is bonded into the east wall. The flooring was of opus signinum over the usual gravel and penning, and at the same level as the secondary flooring of X to XIV. No traces were to be found of an earlier floor. Portions of all four rooms were finished with tessellated pavement of simple design, composed of

small blue liassic $\frac{3}{4}$ inch cubes, arranged in squares and enclosed by two or three rows of white oolitic cubes and, outside the pattern, a broad border of Blue Liassic and Red Sandstone. (FIG. 18). At two points in xv and xvii were fragments of another floor, 6 inches above that described, composed of small $\frac{3}{4}$ inch red, white and brown cubes in concentric circles and with a straight border of larger ($1\frac{1}{4}$ inch) white cubes.

The area of xix was apparently divided by walls of which part project from its south side. The apartments were heated by hypocausts whose furnace or stoke hole was continued within the building. The west wall (excepting ixB) is thicker than elsewhere, both are parallel to and near the ditch towards which the ground sloped in Roman times.

Although when describing the north wing, we ventured to point out that the group of apartments closely resembled on plan the common provision for bathers, we would here remark that the area they occupy is proportionately excessive, and the attribution scarcely to be entertained unless our excavated buildings are to be regarded as possibly something more than a private villa—or alternatively that there may be unexplored remains to which the bathing accommodation could be sensibly related. A further possible allocation of the functions served by the rooms must not be overlooked, namely that viii and ix may have been adapted for use as a frigidarium (with cold bath) after the erection of the new (I and II) caldarium and tepidarium; and the rooms iv, v, vi, added to the domestic apartments.*

* In 1886 the late G. E. Fox completely planned the remains of Chedworth Villa and contributed the result of his investigations to the *Arch. Journ.*, XLIV. Therein he ascribed a portion of the north wing as suited, and no doubt intended, for carrying on the trade of a fuller. In 1904 after exhaustive study abroad and at home of the accommodation necessary for the purpose of fulling, he wrote a paper on the subject copiously illustrated and printed in *Archaeologia*, LIX, among the examples shown being that at Chedworth. Therein Mr

Fox states the requirements as (1) a chamber for cleaning having tanks for large articles and a series of treading stones or wooden troughs arranged against a side wall; (2) tanks for rinsing and steeping; (3) drying and carding spaces; (4) presses and storage.

Although as stated above the remains at Hucclecote are deficient in floors showing the division of the apartments, yet the foundations and broken floor of room IX—of the last building period—do indicate that a solid floor had been substituted for a pillared hypocaust, and a tank, IXb, with strong walls, added on the west side.

Had the plans of Hucclecote been submitted to Mr Fox, the kindest and most helpful of men, whom I knew well, I feel that he would have asked why not chambers I to IX a fulling establishment? The cleaning room being IX, with tanks IXa and IXb for large articles, and the side walls of VIII where treading troughs were ranged. I, with apsidal tanks for rinsing and steeping; II, the drying and carding space, and IV, V, VI for presses and stores.

II. PLASTERS, AND COLOURING MATTER

by Mr Henry Terry, University College, London

In the preparation of the plasters two materials seem to have been used, probably at different periods. In one a mixture of sand and lime has been incorporated with red sandstone. In the other merely sand and lime. The sand, however, in the latter case is of a much coarser variety. (The latter is used in the east centre and in the bath). From small particles of chalk present the lime seems to have been made from chalk. These are all probably of local origin. The tessellated pavement is similar to that used elsewhere by the Romans.

The colouring matter is mineral in origin. No evidence could be found of the use of organic colouring materials. The bluish green is magnesium iron silicate. This is found in Italy and was probably imported. The red colouring matter is red haematite (iron oxide) and the yellow is limonite, *i.e.*, hydrated iron oxide. These, like the bluish green, were imported. All were applied in the form of water colours.

The plaster has in places been covered with a thin layer of lime, and the colours applied on the surface of this lime wash.

III. MORTAR

by the Director of Building Research, Department
of Scientific and Industrial Research

The characteristic appearance of particles of red and brown burnt clay (perhaps crushed tiles or potsherds) so often found in really hard specimens of Roman pozzolanic mortar could be recognized in all the specimens submitted for examination.

The fine white silica sand, with rounded grains of fairly uniform size, is common to all specimens ; some showed indications of a dirty fine aggregate having been used, which may have been a mixture of this sand with loam or simply with lightly-burnt clay used as a pozzolana. This dirty fine aggregate is probably responsible for the darker colour of these specimens. In general, the colouration is due to oxide of iron, giving the buff tint noted in all specimens.

IV. SLAG, AND METAL OBJECTS

by Sir Harold Carpenter, Imperial College of Science
and Technology

The slag is very variable in composition and I do not think it is possible to draw any conclusions from these results with regard to the origin of the ore from which the iron was made, and even if the composition had been regular, I still do not think it would have been possible to relate the material to the Forest of Dean ore-field. The only chance of doing this would be if such material contained some constituent in an unusual amount in the ore as a regular feature. In this case the samples of slag could be examined to see whether they contained any notable amount of this constituent. I find, however, that the Forest of Dean ores do not contain any constituent of this kind. So far as the slag

therefore, is concerned, I do not think that any definite conclusion can be drawn from it except that it is extremely irregular in composition, as would be expected on the assumption that the material dates from the Roman occupation period.

Another class of material was present among the samples. This was obviously corroded metal, and in one or two cases it is possible to infer what the implement was. Clearly one of these specimens is a long nail. Two others are probably portions of chisels. On examining these I was interested to find that in the interior they contained unoxidized metal and I have been examining this. Three micro-photographs magnified at 100 diameters show the structure of the material. Micro 1 is composed of nearly pure iron, micro 2 is iron containing about 0.2 per cent. of carbon, while micro 3 contains nearly 1 per cent. of carbon and is almost a steel. All these were found in one material. I may say that this variable composition of the metal is a common feature of iron made by the early processes and is due mainly to irregularities in the operation of the crude furnaces which were used.

V. STAMPED TILES AND GRAFFITO SKETCH

I. Inscribed Tile (FIG. 21, 2).

Mr Christopher Hawkes, F.S.A., of the British Museum, after consultation with Mr R. G. Collingwood, F.S.A., (both gentlemen having inspected the original) writes as follows as to the stamped tile FIG. 21, 2:—

‘ Fragment of the centre of a reddish well-baked tile, $1\frac{1}{2}$ inches thick, stamped

R P G I \
P A $\overline{\text{E}}$ F I \ . . .

'The first three letters associate the stamp with the series from the Gloucester district which have been interpreted by Haverfield (*Eph. Ep.* ix, iv, 1283-4) as municipal tile-stamps of the Gloucester *colonia*, the letters R P G standing for *R(ci) P(ublicae) G(levensium)*. One tile stamped with R P G only, was published in that place by Haverfield from the Hucclecote villa itself (*loc. cit.* 1283 b), as having been found among the remains of the building. Along with them he published three others (1284 a, b, c) where the R P G is accompanied by other letters indicating in two cases at least the names of magistrates of the *colonia*, *quinquennales* (1284 a), or *duumviri* (1284 b).^{*} Another example, though the reading is less clear, was published in *Eph. Ep.* iv (p. 207), 699, from Gloucester itself (communicated by John Bellows), and another was found on the site of the Barnwood cemetery and published in Mrs Clifford's report in these *Transactions*, 1930, LII, 229, pl. xi. The latter example, though imperfect, seems to have included the names of *duumviri*, and the present specimen certainly also did, the I following R P G being the beginning of the habitual abbreviation IIV(*iris*), followed by the magistrates' names (in abl. abs.). What the names are is unfortunately not clear. The reading . . . p a ê t f i . . . is certain, but gives no clue to the missing letters. The frequency of these municipal tile-stamps in the district gives some hope that a completer duplicate will one day supply the names in full, so as to add to the brief list of known names of these *duumviri*, who were, of course, the chief magistrates of the *colonia*, corresponding in its municipal government to the consuls of the Roman Republic. Also, the distribution of such tiles in the district should serve as a clue to the extent of the *territorium* of Glevum in the surrounding country'.

* A number of the inscribed tiles found 1910/11 were deposited by the Bristol and Gloucestershire Archaeological Society in Gloucester Museum (see *General Guide to Museum*, 1914, p. 10).

'There were also several fragments of tiles stamped RPG only, though in at least one case breakage makes it impossible to say whether there were originally more letters. The similar one published by Haverfield (*Eph. Ep.* IX, iv, 1283 b) from this site has been already mentioned. His other examples (*ib.*, c, a) are from the Ifold 'villa rustica' (*Trans. B.G.A.S.*, xxvii, 168), and from The Cross at Gloucester (found 1894: *ibid.* XIX, 155: *Academy*, 10 March '94, 7), and probably the tile from Dry Hill near Cheltenham (*Eph. Ep.*, iv, 700), and the other tile from The Cross at Gloucester (found 1893: *Trans. B.G.A.S.*, XIX, 154) on which the letters were, he suggested, not correctly recognized. The preceding paragraph leaves nothing further to be said about these at present'.

'FIG. 21, 3, illustrates a specimen of the seven examples of tiles with the inscription T P F A. The other known occurrences of these are all from the Gloucester neighbourhood; see *Corpus Inscr. Lat.*, VII, 1242, b-g, from Rodmarton (*Arch. Journ.*, II, 42; *Archaeologia*, XVIII, 116; Lysons, *Reliq. Brit.-Rom.*, II, i, pl. 9, fig. 5) and from Church Piece near Bisley. The meaning of the letters is unexplained, but the initial T is thought to mean Tegula ('tile'). The stamp was thus probably that of a private tile-manufacturer, whose name is concealed in the letters P F A. Here then we have a contrast to the municipal R P G stamps'.

'FIG. 21, 1, illustrates a specimen of the five examples of tiles with the inscription T C M. T should stand for Tegula here again, and the stamp must be that of another local tile-manufacturer, as the only other published specimen seems to be that from Cirencester (*Corpus Inscr. Lat.*, VII, 1242 a: *Arch. Journ.*, VI, 321)'.



FIG. 21. HUCCLECOTE VILLA : INSCRIBED TILES (see pp. 350-2)

Figs. 21-24, *pl.* Hugh Walwin



FIG. 22. HUCCLECOTE VILLA : *GRAFFITO* SUGGESTING ELEVATION
OF BUILDING (see p. 353)

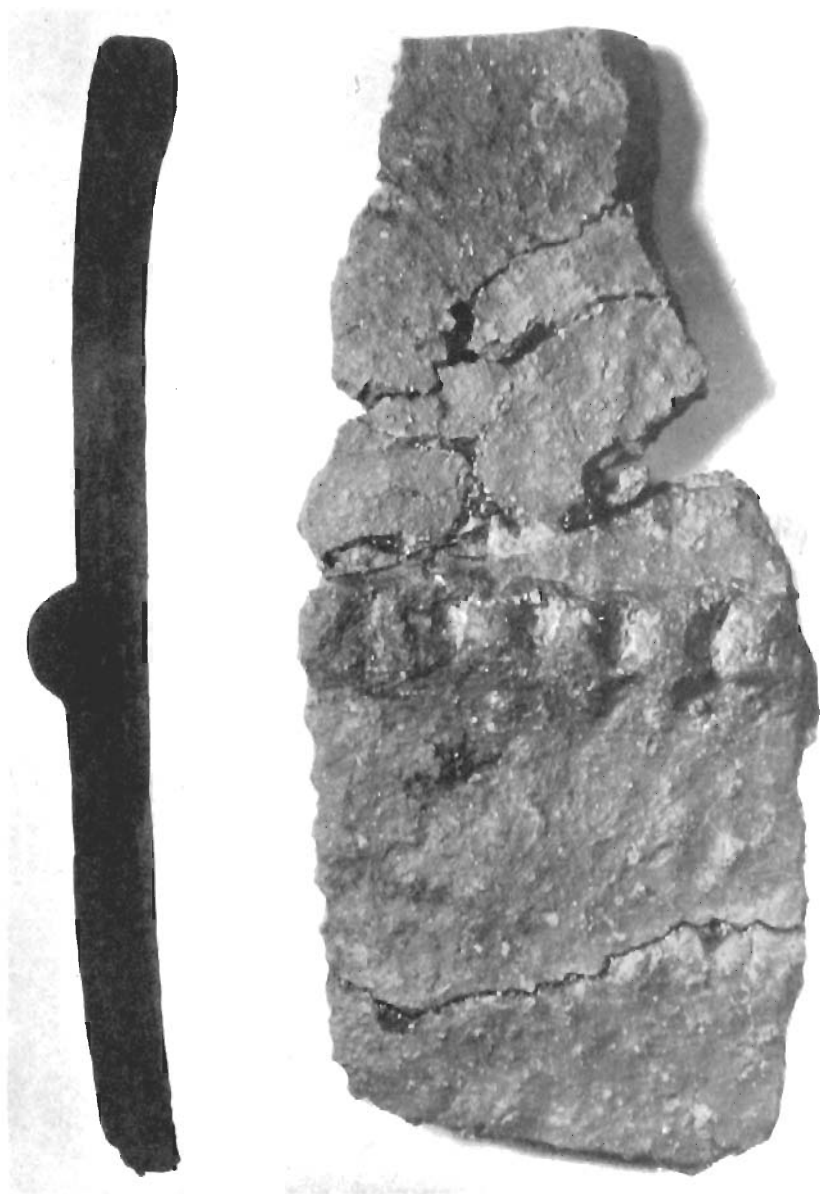

FIG. 23. HUCCLECOTE VILLA : DEVEREL-RIMBURY POTTERY (*see* p. 332)



FIG. 24. HUCCLECOTE VILLA : EARLY IRON AGE POST-HOLE, ROOM XV (*see* p. 334)

2. Fragment of Wall-plaster with part of a *graffito* sketch of a building (FIG. 22)

Mr R. G. Collingwood kindly reports on this interesting fragment as follows :—

‘ The *graffito*, which I have looked at repeatedly in various conditions and moods, strikes me as genuine. Both by the state of the scratches, which appear to have been made a very long time ago (there is nothing fresh about them, and their stained and weathered insides contrast most significantly with the whiter, cleaner surface underneath flakes that have come recently off the face of the plaster), and by the subject of the drawing, which is totally unlike what any modern forger would have drawn, I am sure that it is ancient work ’.

‘ Perhaps I should add that if I understand it rightly it represents the gable-end of a “ half-timbered ” house with round-headed windows: one can imagine the spaces between the timbers filled with brick or (much more probably) plaster. The general proportions (for it is clear that the top of the gable comes at the top of the fragment) point to a single-storey house, and the most obvious way of completing the sketch is as per enclosed. Though of course it need not be a corridor villa’.

Mr Hawkes adds : ‘ Mr Collingwood’s sketch represents a corridor villa of the common  plan, the left-hand gable-end being that shown in the *graffito*. It is obvious, however, as he remarks, that the gable-end would fit a variety of plans, and it would not be difficult to make the sketch correspond to one of the “ elevations ” of the Hucclecote villa itself, which must, above its “ sleeper ” walls of stone, have been built in this half-timbered technique. The representation is unique in Britain, and deserves a full measure of attention’.

VI. POTTERY

SAMIAN WARE

Rims of seven vessels, forms 31 and 33, 1st century.

Rims, forms 18/31, 29, 31, 33, 36, 37 and 38, all 2nd century.

No. 1.—Fragment of late Lezoux bowl (FIG. 20), form 37, late 2nd century, with large medallions, the enclosed figure a Triton wielding a paddle (Déchelette, no. 16, cf. Knorr, *Rottenburg*, pl. xviii).

No. 2.—Samian dish, Ludowici's form Ta, *Stempelnamen* (1905), p. 3, no. 386: Stamped in centre of base AIS[TVS] FECIT in a ring round a rosette: potter AISTVS, of Rheinzabern, late 2nd century. Diameter, 10 inches. (FIG. 25, no. 2).

JARS (FIGS. 25, 26)

3. Bottle-necked jar with widely out-curved rim and cordon at base of neck, soft, pink clay with grey core. May, *Stratford*, XXI, 19.
4. Neck of jar, dark grey, hard, 2nd cent., room XIX.
5. Jar, with recurved rim and distinct neck, brown, smooth, soft, 1st cent. Barnwood, *BGAS*, LII, 232, fig. 4; Alchester, *AJ*, VII, 177, fig. 8, no. 5.
6. Similar, brown, smooth, soft, burnished band below neck.
7. Jar, burnished, brown to black, sharp shoulder below lip inside.
8. Similar, hard, brown-grey.
9. Jar, bead-rim type, should be late 1st cent., found under all floors, room X. Hinksey Hill, *BAA*, N.S. XXXVI, 385, no. 57; Barnwood, *BGAS*, LII, 240, fig. 32.
10. Jar, recurved rim and round shoulder, colour coated pink. Runcton Holme, *PSEA*, VII, 248, fig. 31.
11. Jar, black burnished, room V. Barnwood, *BGAS*, LII, 240, fig. 31.

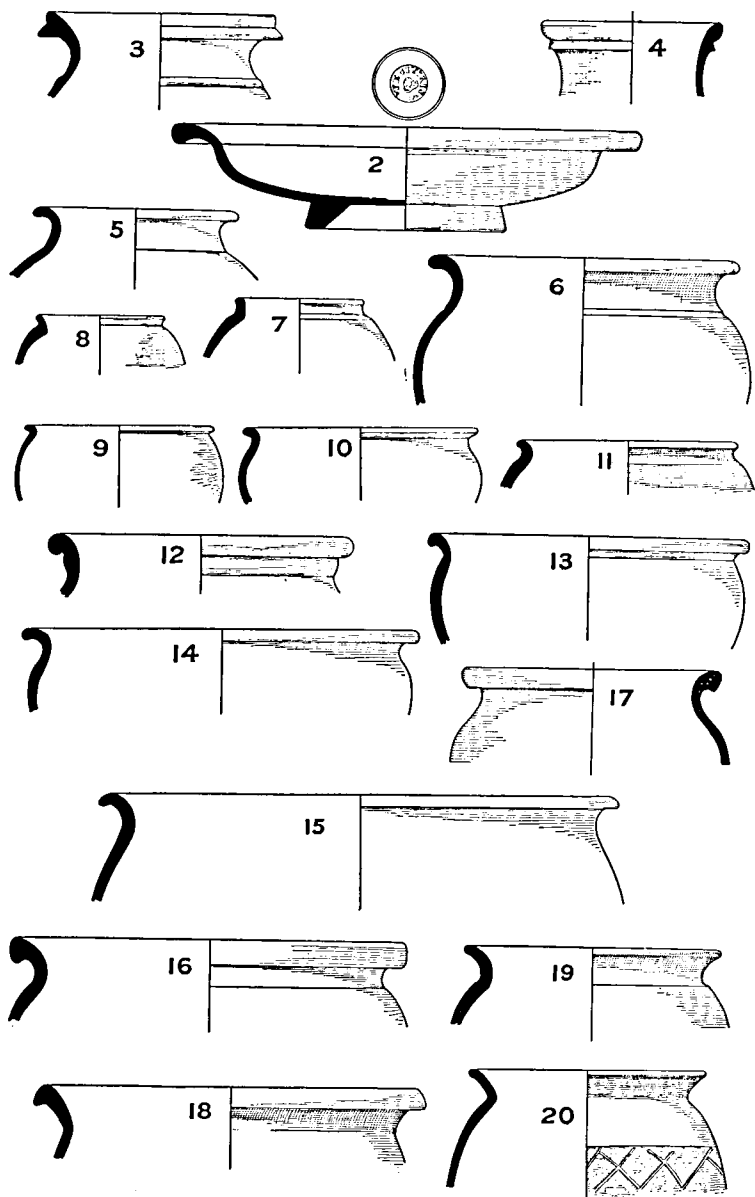

Fig. 25 (see pp. 354, 356)

12. Jar, hard, grey, 1st cent., under floor of room XIX.
13. Jar, brown with grey core, smooth. Hinksey Hill, *BAA*, N.S. XXXVI, 383, fig. 46.
14. Jar, smooth, brown with grey core.
15. Jar, brown washed, soft. Richborough, 1st report, fig. 61.
16. Jar, pink washed, under floors of room XVI. Barnwood *BGAS*, LII, 234, fig. 9.
17. Similar, under floor room XIX.
18. Similar, hard, smooth, brown, 2nd cent., under two floors of room IV.
19. Jar, bitumen coated, hard, black.
- 20-34. Ordinary cooking pots, common to late Roman sites. They show the tendency for the rim to overhang the bulge which is decorated with scored diagonal latticed lines on an unsmoothed zone, brown black clay. Lydney report, 32-5, and 37; May, *Stratford*, xxv, 82, 83 and 84; *JRS*, xviii, fig. 19, no. 1; Wroxeter, II, report, fig. 67; Collingwood, *Roman Britain*, no. 73; Westland, Yeovil, *Procs. Somerset Arch. Soc.*, LXXIV, plate G, fig. 16, where they are late 4th or 5th cent.
35. Small jar, hard black ware.

PIE DISHES (FIGS. 27, 28)

A vast quantity of pie dishes were found and those illustrated are typical of the site.

36. Hard grey rough ware, smooth inside. Barnwood, *BGAS*, LII, 240, fig. 39; Silchester, plate LXVI, fig. 199; May, *Stratford*, fig. 97, where they are all 1st cent.
37. Similar to above but of hard black clay, found under two floors of room v.
38. Similar but brownish black, scored lines on outside.
39. Similar, brownish black.

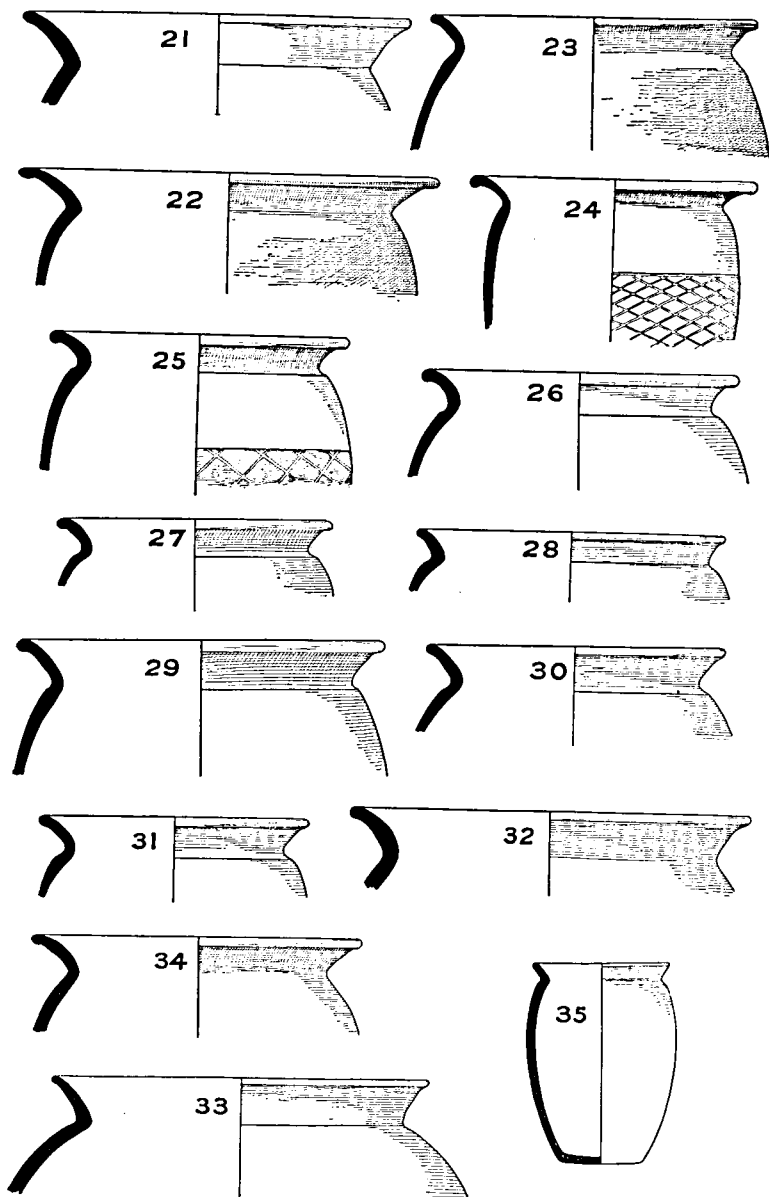

Fig. 26 (see p. 356)

40. Hard, black, under floor room XVI, late 1st cent. or early 2nd cent. ; Richborough, 1st report, fig. 46.
41. Hard brown colour, about mid. 2nd cent. from beneath floor of room III.
42. Black, burnished, hard.
43. Hard black, under floor room VI. Runcton Holme, *PSEA*, VII, pl. II, p. 239, fig. 14.
44. Hard brown. Richborough, 1st report, fig. 122, 4th cent.
45. Similar but hard black, burnished lines on outside. Westland, Yeovil, *Procs. Somerset Arch. Soc.*, LXXIV, plate G, no. 18.
46. Hard grey rough ware. Heywood Sumner, *Sloden*, XVIII, fig. 5 ; May, *Colchester*, fig. 257 ; May, *Silchester*, LXVI, fig. 201.
- 46a. Similar. May, *Colchester*, fig. 256.
47. Hard black ware. Lydney report, no. 43.
48. Bitumen coated, hard, black, unusually thick and coarse, 3rd to 4th cent. Thunderbarrow Hill, *AJ*, XIII, p. 141, fig. 20 ; Sumner, *Ashley Rails*, XII, nos. 10-14 ; Sumner, *Sloden*, XIV, 3-5, 7-9.
49. Dark grey clay, hard baked, black coated.
50. Brownish grey coated black.
51. Grey, rough surface.
52. Grey, smooth, hard, well made.
53. Grey, coated with black.
54. Grey, coarse.
55. Grey clay, smooth, burnished, brown coated.
56. Hard black ware. Lydney report, no. 43.
57. Smooth brown, well made.
58. Hard grey rough ware, late 1st or early 2nd cent. ; Richborough, 1st report, fig. 85 ; Lydney report, no. 46 ; Barnwood, *BGAS*, LII, 240, fig. 38 ; May, *Stratford*, fig. 112 ; May, *Colchester*, fig. 274.
59. Hard black bitumen coated, burnished, is scored round the outside with unusual crosses.

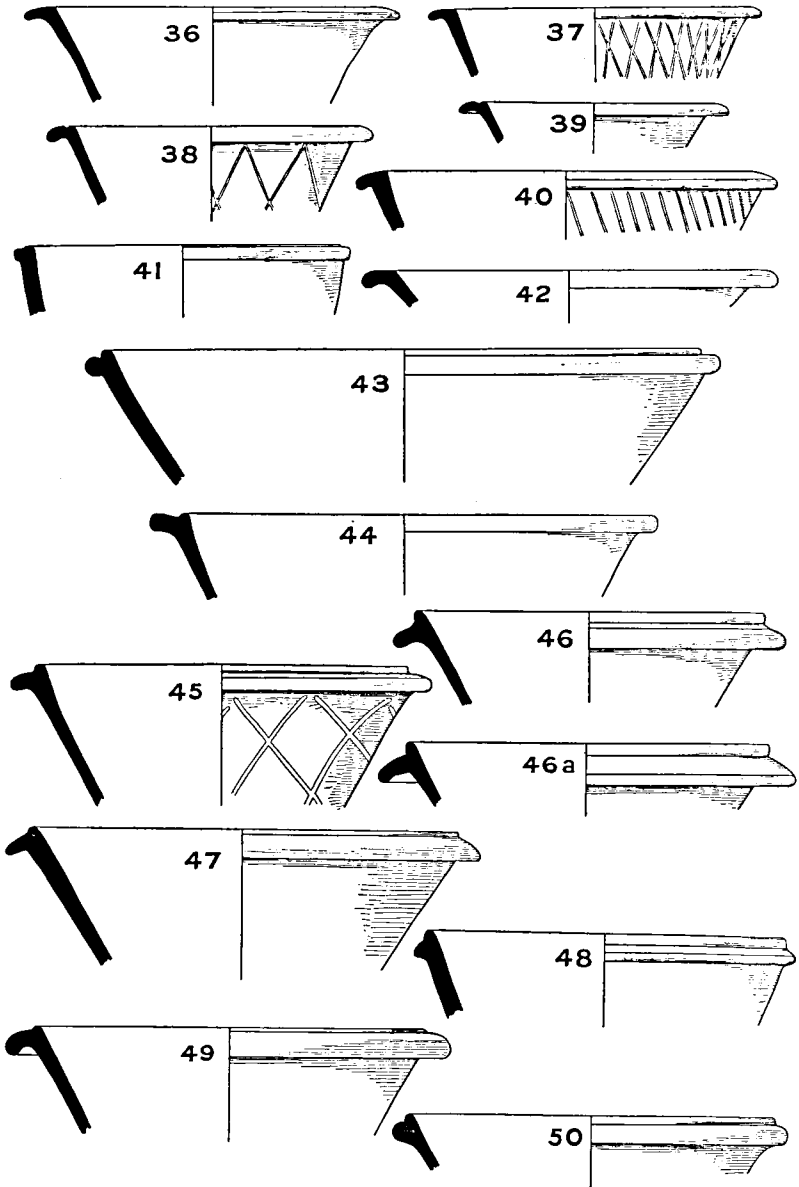

Fig. 27 (see pp. 356, 358)

60. Brown dish, dark grey core, hard.
 61. Black dish, hard, burnished. May, *Colchester*, fig. 274; Collingwood, *Roman Britain*, 224, fig. 36; May, *Stratford*, fig. 110.

BOWLS AND VASES (FIGS. 28, 29, 30)

62. Handled bowl of soft pink clay, 2nd cent., found in room I.
 63. Bowl, soft, brown with grey core.
 64. Bowl, soft red clay. May, *Colchester*, fig. 300; dated 2nd cent.
 65. Pedestal base, fairly hard, brown, almost exactly similar one is figured in Lydney report, no. 22.
 66. Vase of hard grey clay, well made and well burnt, found under floor of room II, late 1st or early 2nd cent.
 66a. Bowl, white clay, painted bands in red. May, *Silchester*, LV, fig. 4; May, *Stratford*, fig. 88.
 67. Funnel necked vessel of Rhenish type from Caistor potteries, 3rd and 4th cent. Lydney report, nos. 60 and 61.
 68. Part of neck of vase, pinkish brown clay with sharp ridge between neck and shoulder, and burnished vertical and arched lines showing darker against buff ground.
 69. Fragment of vase, pink clay with large quantity of shell, grey coated, wavy lines between double girth grooves. May, *Colchester*, LXII, fig. 295.
 70. Fragment of cooking pot, black coated with burnished parallel lines and lattice pattern on bulge, roughly executed.

IMITATION SAMIAN AND LATE RED COATED WARE (FIGS. 29, 30)

71. Fragment of rim of bowl imitation Samian form 35, decorated with pattern in white paint, late 3rd or

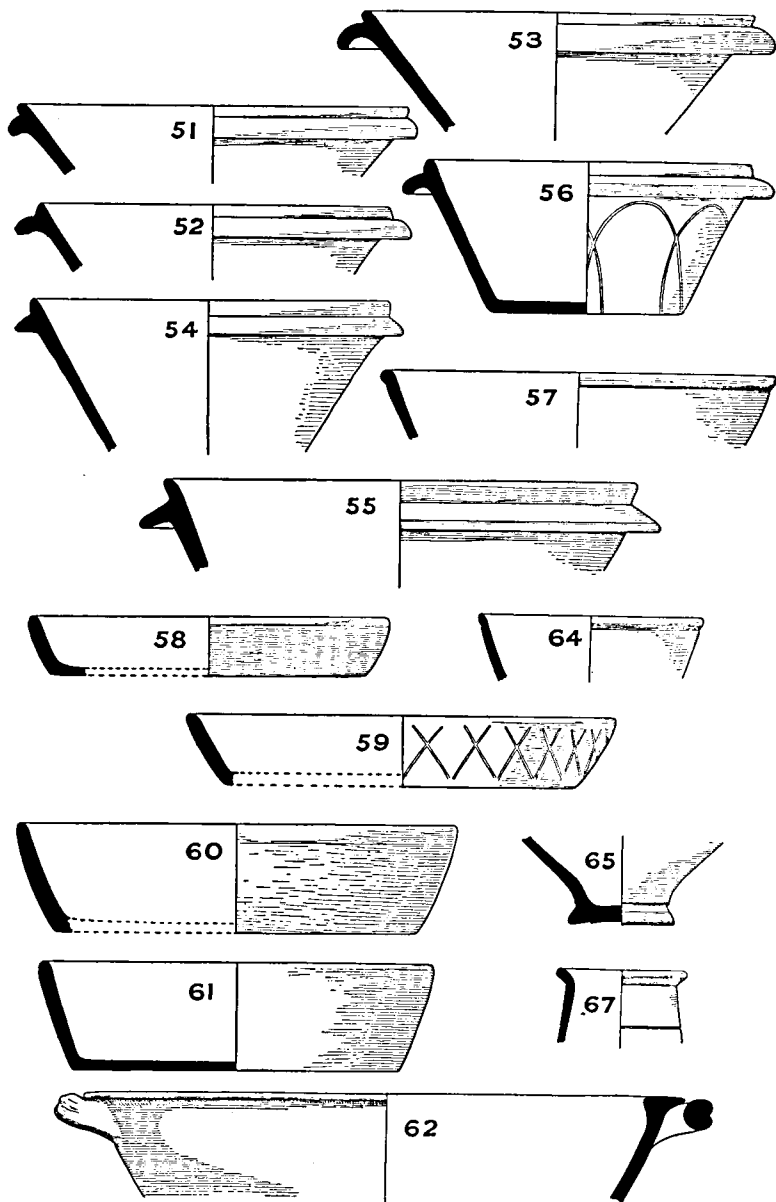

Fig. 28 (see pp. 358, 360)

- 4th cent. Ashley Rails, VII, fig. 2 ; Richborough, 2nd report, fig. 176 ; Lydney report, no. 26.
72. Flanged bowl (restored), imitating Samian form 38, grey clay coated with deep red smooth slip, late 3rd or 4th cent. May, *Stratford*, XVII, fig. 2 ; Richborough, 1st report, fig. 112 ; Lydney report, fig. 26, no. 24 ; Thunderbarrow Hill, *AJ*, XIII, p. 139, fig. 10 ; Ashley Rails, VII, fig. 10.
73. Similar to above.
74. Fragment of rosette or ' multiple arch ' stamped ware. Ashley Rails, V, fig. 4 ; May, *Colchester*, fig. 185.
75. Fragment of vase, hard brown clay, coated bright red, bead rim with slightly decorated neck and stamped pattern between depressions.
76. Fragment of bowl of soft red clay coated with green ornamented with two bands of roulette stamping. Lydney report, fig. 25.
77. Similar to above but red coated. Westland, Yeovil, *Procs. Somerset Arch. Soc.*, LXXIV, plate F, no. 3.
78. Bowl, hard grey clay, red coated. Lydney report, figs. 48-50 ; Richborough, 1st report, no. 104 ; Richborough, 2nd report, no. 183.
79. Similar to above.
80. Bowl of brown clay, red coated, hard. Richborough 1st report, fig. 127.
81. Fragment of brown smooth ware decorated with three rows of cable pattern.
82. Bowl of hard red clay, red coated, decorated with three rows of roulette markings on neck and stamped pattern below. May, *Silchester*, fig. 99.

WARE OF NATIVE CHARACTER OR TRADITION (FIG. 29)

83. Vase, colour pinkish to almost black, large quantity of pounded shell and grit. Two grooves and wavy scored line, found in room II under floor.

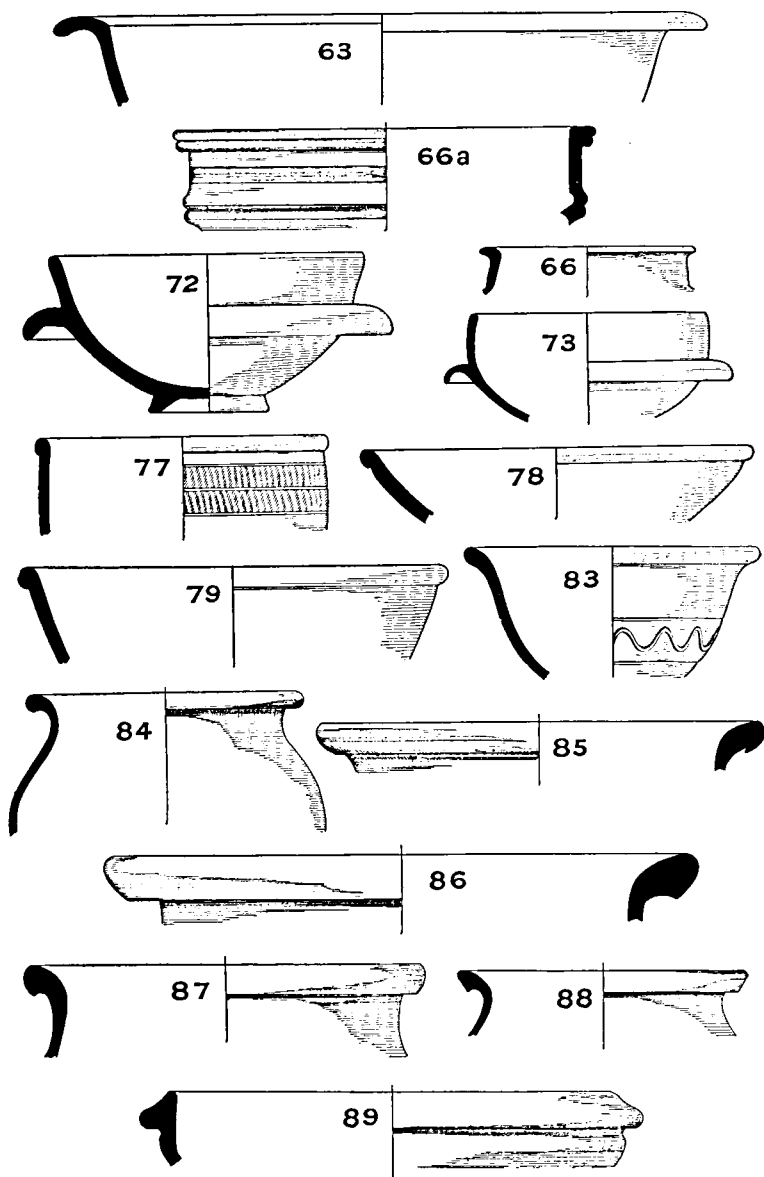

Fig. 29 (see pp. 360, 362, 365)

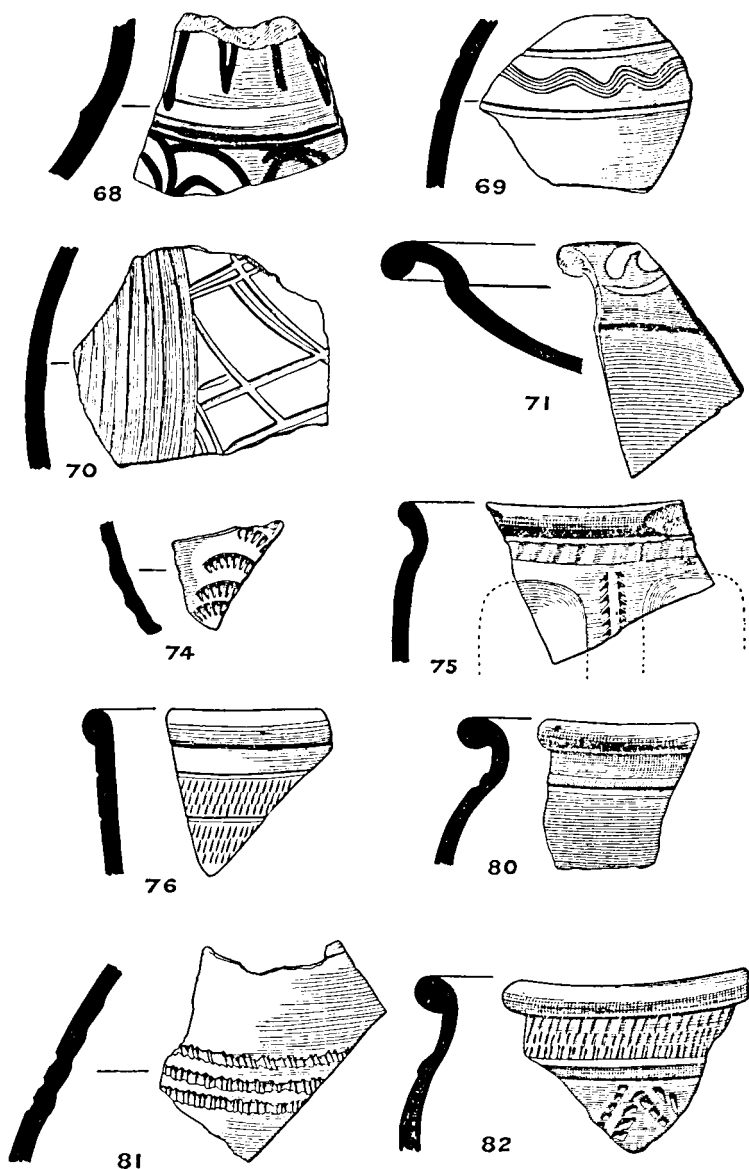

Fig. 30 (see pp. 360, 362)

- 84-8. Jars of coarse ware, pinkish to black, smooth and soapy. May, *Stratford*, fig. 24; May, *Colchester*, LIV, fig. 236; Caistor, *JRS*, XXII, plate VIII, fig. B 2; Runcton Holme, *PSEA*, VII, plate II, fig. 29; Alchester, *AJ*, VII, 177, fig. 8, no. 1.
89. Bowl, coarse grey ware similar to above. Lydney report, no. 23.

Some fragments are early as they were found under all floors, the remainder being scattered over the site, and in all probability late 4th cent., some perhaps early 5th cent.

MORTARIA (FIG. 31)

A large number of mortaria were found and these are typical of the site. They are chiefly of white clay and are of 3rd and 4th cent. date.

90. Lydney report, fig. 26, no. 18.
91. May, *Stratford*, XXIV, no. 75.
92. Red ware. Richborough, 1st report, fig. 100.

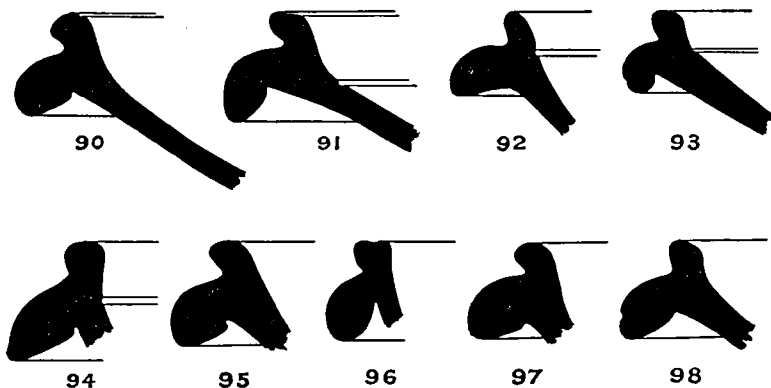

Fig. 31

93. Red ware.
94. Ashley Rails, plate x, type A (not decorated).
95. Wroxeter report, 1, fig. 20, no. 150; Richborough 1st report, fig. 101; Alchester, *AJ*, XII, p. 58, fig. 10.

96. Wroxeter, fig. 158.
 97.
 98. Crock-Hill, Sumner, *New Forest Pottery*, plate xxxi, no. 18; Richborough, 1st report, fig. 102; Westland, Yeovil, *Procs. Somerset Arch Soc.*, LXXIV, plate G, no. 14.

VII. COINS

by C. H. V. Sutherland

Mr Sutherland took great pains to prepare a detailed description of all the coins found. Owing to limitation of space it has not been possible to print this, but the list has been deposited in the Gloucester Public Library for consultation.

The small group of coins from Hucclecote is composed as follows:—Trajan (1), Geta (1), Numerian (1), Carausius (1), 'Constantinopolis' (1), Constantine II (? 2), Constantius II (1), Constans (1), uncertain Constantinian (3), Valentinian I (1), Valens (3), Gratian (2), Theodosius (? 3), Arcadius (1), Honorius (probably) (1). Two are illegible and unidentifiable, perhaps of the Constantinian and Theodosian periods respectively. With these coins was found one lead token, probably of late medieval origin.

It is clear from the frequency of coins of the Constantinian period, as compared with those of an earlier date, that the occupation of the site cannot be dated much before A.D. 300. From this period onwards the coins are fairly steadily represented, and it would appear that occupation was prolonged considerably beyond the end of the 4th century A.D., since the coins of Theodosius, Arcadius and Honorius have all been subjected to a good deal of wear.

Little light is thrown on the distribution of mints: the exergues are nearly all either illegible or off the flan. A few, however, are legible: the Numerian *antoninianus* is of Ticinum, and both the coins of Gratian are of Arclate. In the case of the coin of Carausius, the reverse is much

damaged, and it is impossible to read the exergual mark with any certainty, though the probability is in favour of its being that of Londinium.

The most interesting coin is, perhaps, the plated *denarius* of Geta (no. 2). The copper core, which is of an irregular shape, is almost certainly cast, and we are reminded of what has for long been on record,²⁹ namely, that in some districts, as at Lingwall Gate, coin-moulds were used for casting copper cores, suitable for plating over with base alloy of silver. It is, moreover, worth remarking that the present site is not very far removed from Somerset, in which county many moulds have been discovered at Edington.³⁰ Leaving aside the question of the responsibility and motive for coin-casting in Britain, we may at least say that this *denarius*, probably of British manufacture, gives an excellent illustration of the process: the plating is thin, and of a whitish, tin-like colour. The coin is, incidentally, a variant of Coh. 157 in the matter of its obverse legend, which further supports the probability of its having been cast.

Otherwise there is little in this group of coins which suggests local manufacture, though the 'Constantinopolis' coin possesses a reverse in unusual style, showing Victory nearly facing, which may be the product of a local mint. In general, the proportion of local issues is much below what is usually found at this period, *e.g.*, at Chedworth.

VIII. HUMAN REMAINS

by Miss M. L. Tildesley, Curator of Human Osteology,
Royal College of Surgeons

The human remains sent for report consist of the imperfect skull of a woman aged probably 45 to 55 ;

²⁹ Cf. Reade, *Num. Journ.* II, 58 ff., quoted in Akerman, *Coins of the Romans Relating to Britain* (1844), pp. 95 ff. ; cf. especially p. 100.

³⁰ Cf. Akerman, *op. cit.*, pp. 70 ff. I am indebted to Dr J. G. Milne for this suggestion.

the middle part of the lower jaw of a child aged 8 to 9 years ; two vertebrae and nine fragments of adult long bones that are apparently male and may belong to the same individual ; two fragments of skull and five fragments of long bones that may also belong together, and would be derived from a rather smaller adult probably not more than thirty years old.

These remains were not found all together and we must first examine the evidence for dating them, as far as it is available.

1. The imperfect skull came from trench 1, on the west side of the villa, 5 feet 6 inches deep, lined with puddled clay, and containing only Roman material except in the final top filling. The bulk of the Samian sherds (1st and 2nd century) were found in this trench ; and the skull, being 4 feet from the surface and therefore in the lower part of the filling, and definitely not dug in there, would presumably have come into the ditch in the earlier part of the Roman occupation. No other parts of the skeleton were found : only the greater part of a cranium and two portions of a lower jaw which definitely belonged to it. Either, therefore, these were thrown in as not less than two separate ' bones ' (or four separate pieces if what we have is all of the skull that was in the ditch) ; or else a detached head was thrown in. The latter possibility however is not one to be stressed without further evidence, and it must be pointed out that a head usually has some neck vertebrae attached—of which none were found. Most probably therefore these bones entered the ditch as parts of a disturbed skeleton, at a date which would be determined by the artifacts found in the same horizon ; and if these were the 1st and 2nd century Samian sherds referred to, we can infer that the individual whose imperfect skull is the subject of this enquiry was already a skeleton in the 2nd century A.D., and may have died many centuries before.

The earliest period represented by a settlement on the site can be ruled out by the Late Bronze Age habit of cremation. But the evidence to hand would as readily permit us to attribute the skull to one of the Early Iron Age settlers whose probable occupation is indicated by a post-hole under room xv, and pottery fragments from trench, under room v, as to one of those who occupied the site in the 1st century A.D., or even as late as the early 2nd century. She would however be not Roman but native British, for the Romans practised cremation during the earlier part of the occupation.

When we look to the skull itself we find it entirely consistent with what we know of the Briton of the Roman period (evidence for the pre-Roman Iron Age is very scanty), but there is no sharp distinction between this and succeeding populations that would enable us to identify this definitely as a British skull on its own testimony. It exhibits no extremes: its maximum length (177 mm.) and breadth (139 mm.), its cephalic index (78.5 mm.), its minimum frontal breadth (97 mm.), horizontal circumference (504 mm.) and sagittal arc (373 mm.) all show very ordinary values. The upper face is missing but for the right cheek bone and the right half of the dental arch; and the lower jaw also is imperfect. No teeth had been lost during life out of the sixteen of which we have evidence, though there was an abscess at the root of the right upper wisdom tooth, and of the three teeth that have not been lost post mortem, one (a first molar) has a small carious hole, the other two being healthy.

2. The imperfect jaw of a child is reported to have been found just outside the wall of the corridor on the east side of the house and on a level with the bottom of its foundations. Presumably it found its way there when the foundations were dug at the rebuilding of the villa in the 2nd century A.D., in which case the limiting dates of the

child's jaw become the same as for the woman's skull, *viz.*, Early Iron Age to early 2nd century A.D.

3. The fragmentary remains of at least two individuals which are said to have been found beneath the floor of room XIX would be given a definite limit by the floor itself, and unless this were one of the various later additions and alterations to which reference is made, would presumably date from the rebuilding of the villa in the 2nd century A.D. Our possible range of date thus again becomes Early Iron Age to early 2nd century A.D. But again these fragments cannot of themselves fix the period more definitely.

IX. ANIMAL REMAINS

by J. Wilfrid Jackson, D.Sc., F.G.S., Senior Assistant
Keeper, Manchester Museum

The remains can be separated into those of wild animals and those of domesticated species. The broken condition of the majority of the bones renders it impossible for many measurements to be taken.

The animals represented are red deer, badger, fox, cat, rabbit (probably intrusive), horse, ox, sheep, pig and dog. There are also some bones of fowl.

Comparisons have been made with the remains from similar sites, and especially with those from the Glastonbury Lake Village (Early Iron Age B, 1st century B.C.)³¹; the somewhat earlier sites of All Cannings Cross,³² Swallowcliffe Down,³³ and Fifield Bavant Down,³⁴ Wilts (of Early Iron Age A); and a number of other places

³¹ *Glastonbury Lake Village*, II, 641-72.

³² *The Early Iron Age Inhabited Site at All Cannings Cross Farm, Wilts*, 1924, pp. 43-50.

³³ *WAM*, XLIII, 90-3.

³⁴ *WAM*, XLII, 492-3.

including the Highfield Pit Dwellings,³⁵ Wilts ; Wilbury, Herts³⁶ ; and Kingsdown Camp, Somerset.³⁷

Wild Species

RED DEER. An antler tine, a burnt fragment of antler, a foot bone, a split piece of a metatarsal, a split proximal end of a radius, and part of the shaft and distal end of a tibia.

BADGER. A humerus and the distal end of another.

FOX. A few limb-bones.

CAT. Represented by the shaft and distal end of a humerus.

RABBIT. Fragment of the lower jaw and the distal end of a humerus (probably intrusive).

Domestic Species

HORSE. There are many loose upper and lower teeth representing at least three animals. A left premolar 4 possesses a short pillar, as in the ' plateau ' or *Equus agilis* type of Ewart.³⁸ In all the others, the pillar is long, as in the ' Forest ' or *Equus robustus* type of Ewart. Two second premolars, a left and a right, are unworn : a well-worn milk-molar fits on to the left tooth. The associated third premolar is unworn. There is also a symphyseal fragment of a lower jaw. Among the few limb-bones (mostly broken) are one or two of interest. Two metacarpals without proximal ends are larger than the series from Glastonbury, All Cannings Cross, and Swallowcliffe ; and a metatarsal, measuring 264 mm. in length with a mid-shaft diameter of 30.5 mm. is larger than the Glastonbury series. It is midway in length between two from All Cannings Cross, and longer than

³⁵ Not yet published.

³⁶ Not yet published.

³⁷ *Archaeologia*, LXXX, 95-7.

³⁸ J. C. Ewart, ' The Animal Remains at Newstead ' in *A Roman Frontier Post and its People*, by James Curle, 1911.

examples from Swallowcliffe (260 mm.) and Highfield (260.5 mm.). The Highfield specimen, however, is more robust and belongs to the 'Forest' or *Equus robustus* type. The Hucclecote metatarsal is somewhat slender, with a length-width index of 8.6, and may indicate an animal about 13 hands high at the withers.

Ox. The remains are more numerous than those of any other animal. They consist of split and broken bones as well as teeth and fragmentary jaws. Two small horn-cores are of the Celtic ox type (*Bos brachyceros*, Owen). All the four metacarpals are imperfect, but three indicate larger bones than at Glastonbury, All Cannings Cross, Swallowcliffe, and Whitehawk Camp (Neolithic).³⁹ They are near some from Woodhenge.⁴⁰ The fourth example is more slender and like others found at Glastonbury and other places. Three of the five metatarsals are perfect and measure 237, 213, and 211.5 mm.: they are robust bones and larger than any from Glastonbury, All Cannings Cross, and Swallowcliffe, but agree with some from Woodhenge. A distal fragment of another is much more slender. The other fragmentary limb-bones are large and robust and agree better with the Woodhenge series than with those of the Early Iron Age. A left femur, left tibia, and two left humeri agree with similar large bones found among the smaller and more numerous series from Glastonbury. Among the jaw fragments and teeth are one or two of interest. There is a tendency towards the deterioration of the third column in the last true lower molar in several cases. In one or two jaws this column is very rudimentary. This peculiarity has been noted in earlier remains. In a lower jaw of a small ox from Swallowcliffe the third column was completely suppressed, and in a jaw from the Glastonbury

³⁹ *Antiq. Journ.*, xiv, 128.

⁴⁰ *Woodhenge*, 1929, pp. 64, etc.

Lake Village the column was rudimentary.⁴¹ In two of the lower jaws from Hucclecote there is also a small socket for the second premolar, showing a tendency towards early loss of that tooth. Many of the ox jaws at Glastonbury had lost this premolar and the alveoli had become closed. This also obtains in one of the jaws from Woodhenge. The Hucclecote jaw fragments seem to indicate jaws of large size not unlike those from Woodhenge—a much earlier site: they are more robust than those from Glastonbury and the other Early Iron Age sites.

SHEEP. A few loose teeth and fragmentary lower jaws; an axis vertebra; some fragments of limb-bones, including metacarpals and metatarsals like those from Glastonbury, etc. There are also two horn-cores.

PIG. A few bones, loose teeth and fragmentary lower jaws. They agree with similar remains from Glastonbury.

DOG. There are a few bones of different sized dogs. The most interesting of these is a short and stout left radius which is bent: the bone has a length of 112 mm. and a mid-shaft diameter of 15 mm. It shows some knife-cuts, as in those from Highfield. Two small femora (111.5 and 119 mm. long) suggest a dog of the terrier class. A fragmentary lower jaw with teeth seems to indicate a dog of the type of a retriever.

FOWL. Fragmentary bones including the spur of a cock.

X. BIRD REMAINS

by Miss M. A. Bate, Department. of Geology, Natural History Museum

1. *Corvus corax* Linn. Raven, 1 imperfect ulna.
2. ? *Anser* sp. Goose, 1 imperfect furculum.
3. *Vanellus* Linn. sp. Lapwing, 1 imperfect humerus.
4. *Gallus*. Domestic Fowl, 12 limb bones.

⁴¹ See my paper in *Ann. Mag. Nat. Hist.*, March 1915, pp. 291-5

The distribution of the raven in this country has undoubtedly been reduced to its present limits comparatively recently, and this bird was probably common throughout the greater part of Britain during Roman and earlier times. Bones of ravens have been obtained from a number of cave-deposits in both England and Ireland, and also from many Roman sites.

It will be seen from the list given above that the domestic fowl is represented by the largest number of specimens. These include bones of birds differing greatly in size, and it seems possible that more than one breed of fowl was kept. *Gallus* remains are sometimes found in caves where, through disturbance of the superficial layers, it is usually impossible to ascertain the geological age of the specimens. Bones of domestic fowls are commonly found in Roman sites, and quite recently a bone of this bird has been obtained from a pre-Roman site at Colchester.

XI. MOLLUSCA

by A. S. Kennard, A.L.S., F.G.S.

An unusually large number of oyster, mussel, and snail shells were met with, and Mr M. A. C. Hinton, F.R.S., of the Natural History Museum, reports as follows:—*Helix aspersa*, Muller (land snails); *Ostrea edulis*, Linn. (oysters); *Mytilus edulis*, Linn. (mussels). These have been examined in detail by Mr Kennard.

MARINE. Two species were represented, *viz.*, *Ostrea edulis* Linn (oyster), *Mytilus edulis* Linn. (mussel).

A large number of both species were obtained and it is obvious that both were extensively eaten. The oysters were probably obtained from the mouth of the Severn by dredging in fairly deep water, for the shells belong to the deep water form and not to the small estuarine one. Both species were probably brought from some considerable

distance, for in Roman times the mouth of the Severn would have been much further down the now sunken valley.

NON-MARINE. A large number of *Helix aspersa* Linn. were sent and by washing the earth contained within them three more species were obtained, viz., *Arion* sp. (slugs), *Trochulus hispidus* (Linn.), *Planorbis leucostoma* (Mill). This last is a freshwater form and denotes the presence of a pond or pool liable to desiccation in the summer. The occurrence of *Helix aspersa* is of importance, for the true status of this species in England has long been the subject of discussion.

From cumulative evidence obtained from all parts of England it would appear that its advent over practically all England except the extreme west was in Roman times. We know that the Romans considered the larger snails as great delicacies, and in Italy they were reared and specially fed on snail farms or Cochlearia, whilst the cochleare, a special instrument used in their consumption, has been found on many Roman sites. It is therefore extremely probable that the species was intentionally colonized all over Roman Britain as an article of food. *Helix aspersa* occurred with Roman relics on the site of the Girls' High School, Gloucester (*Proc. Cott. Nat. F.C.*, 1908, XVI, 126).

J. W. Taylor has figured a cochleare from a Roman site near Woodchester, Gloucestershire (*Mollusca Brit. Isles*, III, 219).

XII. GRAVEL BEDS

by K. S. Sandford, F.G.S., University Museum, Oxford

Sample A consists of subangular pebbles and fossils derived from the local Jurassic limestone: a minor proportion of small fragments of Liassic ironstone: quartz sand.

The limestone pebbles for the greater part range from $\frac{1}{2}$ – $\frac{3}{4}$ inch in diameter, but some larger fragments are as much as $1\frac{1}{2}$ inches long. These pebbles have a coarse and ungraded appearance and probably have not travelled far.

The pieces of iron-stone, on the contrary, are, in the sample examined, well waterworn, very thin, and do not exceed $\frac{1}{2}$ inch in the length of their longest axis. In this sample they form barely 5 per cent. of a pebble-count (size of pebble being ignored), but this might vary within short distances in the gravel.

The quartz grains are very well rounded and many of them are partially coated or stained by iron oxide. It is probable that they have been derived from some 'solid' formation of sedimentary origin in the district. No other mineral grains were found in the sand washed from a part of the sample supplied.

No pebbles of non-local rocks were found.

Sample B, reported from beds overlying the gravels:—

Grey-brown clay, containing some lime re-deposited in the form of soft white aggregations which may be as large as a small pea. A few subangular limestone pebbles, as in sample A, are included. Washing and settling produced no sand at all, a marked contrast to sample A. This may be a peculiarity of the particular sample, but the distinction should be noted. It is reasonable to suppose that the clay is derived from immediately subjacent Liassic beds and that it has been re-deposited: the absence of contaminating minerals suggests that the clay has been transported only a short distance.